

The **ISO-MAX** PRO series audio ground isolation interfaces are designed for use in the finest professional sound systems. They use the same Jensen transformers installed in tens of thousands of recording studios, broadcast facilities, and sound reinforcement venues worldwide. Jensen audio transformers are industry benchmarks for sonic transparency because of their extremely wide bandwidth, low harmonic distortion, and extremely low phase distortion.

Model PC-2XR is a two channel audio ground isolator designed to convert “pro” to “consumer” levels while solving the following problems, which generally reveal themselves **only** when pieces of equipment are interconnected in a system:

- **Poor noise rejection by the equipment’s existing balanced input.** Most electronic or actively balanced input circuits have high noise rejection or CMRR *only* when driven by laboratory equipment. The CMRR of these circuits is exquisitely dependent on precision matching of impedances in the driving source equipment. *The transformers used in the PC-2XR exhibit very high CMRR when driven by real-world balanced sources, and even unbalanced sources, effectively eliminating noise due to voltage differences between equipment grounds.*
- **Noise due to improper shield pin wiring inside the equipment.** Sometimes called “the pin 1 problem,” this design defect effectively makes the equipment’s shield connection a signal input. Noisy ground currents, which normally flow in the cable shield, then inject hum, buzz, and other noises into the signal path. This insidious defect, which can exist at equipment inputs or outputs, can frustrate attempts to troubleshoot system noise problems because its symptoms are so confusing. *The PC-2XR, via its built-in grounding option switches, can eliminate this problem by interrupting or re-routing shield current flow.*
- **Noise due to the equipment’s susceptibility to RF interference.** Most electronic or actively balanced inputs will exhibit symptoms ranging from subtle audio quality degradation (“fuzzy” or “grainy” distortion) to outright demodulation (heard as voices, music, or other noises in “silent” channels) when RF fields from broadcast or other transmitters are present. *The transformers used in the PC-2XR inherently attenuate signals above about 100 kHz, effectively eliminating RF interference. In addition, built-in resistor-capacitor networks help to control “standing waves” which can make RF pick-up by cables especially severe.*

Model PC-2XR Application Guidelines

Source Impedance Range (<i>output impedance of device driving the ISO-MAX input</i>)	0 Ω to 5 kΩ
Load Impedance Range (<i>input impedance of device loading the ISO-MAX output</i>)	10 kΩ to 10 MΩ
Maximum Recommended Input Level	+29 dBu = 22 V RMS at 50 Hz
	+26 dBu = 15 V RMS at 30 Hz
	+21 dBu = 9 V RMS at 20 Hz
Signal Voltage Attenuation	13 dB

The **ISO-MAX** PI- series, which is available with various connector options, may be driven by either balanced or unbalanced outputs and may be used to drive either balanced or unbalanced inputs. When phase (polarity) inversion is desired in any application, simply reverse connections at the **ISO-MAX** input.

Cables at the **ISO-MAX PC-2XR outputs should be less than 10 feet long !!**

The added capacitance of longer cables can degrade high frequency bandwidth and transient response. Keep the cables as short as possible, although performance is not improved for lengths under 8 inches. Do **not** route the output cables to a patchbay where additional cable lengths will be used to route signals to device inputs. The length limitation applies to **all** cable between each **ISO-MAX** PC-2XR output and the device input which it drives.

PROPER INSTALLATION IS ESSENTIAL TO ACHIEVE OPTIMUM AUDIO PERFORMANCE

PLEASE READ THIS GUIDE CAREFULLY !

General Information About Noises

Hum, buzz, and other noises in audio systems are nearly always caused by so-called "ground loops." A ground loop creates a voltage difference between the ground references (chassis) at each piece of equipment. This voltage can couple into the signal path, especially in unbalanced signal interconnections. Since this voltage is ultimately coupled from the power line, it's usually heard as 50 or 60 Hz "hum" if the equipment has grounded (3-prong) AC plugs. For equipment with ungrounded (2-prong) AC plugs, it's usually heard as a harmonic-rich "buzz" because the coupling mechanism favors high frequencies. **ISO-MAX** ground isolators can eliminate **hum** and **buzz** as well as the intermittent **pops** and **ticks** frequently caused by on/off operation of switches and relays or appliances which contain them.

ISO-MAX isolators cannot eliminate **hiss**, which sounds like a waterfall or an FM radio tuned between stations. A predictable amount of hiss (random or "white" noise) is *unavoidable* in any electronic system. Excess hiss sometimes is the result of improper system gain settings. For example, if the output level control on a CD player were set too low, the downstream preamp would have to operate at very high gain to compensate. Such high gain operation will generally produce more noise at the system output.

Buzz which occurs **only** when an AM receiver is the signal source, and is worse when the receiver is tuned to weaker stations, is probably caused by radio frequency interference or RFI. Power line operated devices such as fluorescent lights, electric motors, computers, and TV receivers produce high frequency interference can be conducted through or radiated by the power line and picked up by the antenna of AM receivers. These problems can often be eliminated by installing power line interference filters as close as possible to the offending source. A portable battery-operated AM radio tuned to a very weak station can be useful in locating the source.

Location, Location, Location

ISO-MAX ground isolators use *transformers* to magnetically couple the signal while breaking the electrical paths between input and output connections. Once these connections are broken, the "ground loop" current, and the resulting noise, is eliminated. Ground isolators are **not** filters which attempt to remove noise from the signal after the fact — they eliminate the cause of the noise coupling. **For this reason, an ISO-MAX ground isolator MUST be inserted into the signal path where the noise coupling actually occurs.**

As a general rule, noise coupling most frequently occurs at interconnections using the longest cables. Problems are most severe, even with short cables, when the cable connects two pieces of equipment which both have grounded (3-prong) power connections or there is another ground connection (CATV, DSS, grounded rack, etc.) somewhere in the system. **NEVER defeat the safety grounding provided by a 3-prong power plug, whether with a "3 to 2 ground adapter" or by removing the plug's grounding pin.** This practice is not only illegal, it can result in shock trauma or electrocution of persons touching equipment anywhere in an interconnected system. *Detailed technical papers on the subject of system grounding and its effects on signal interfaces are available from Jensen Transformers.*

The following method (as opposed to "trial and error") will save time, labor, and frustration when selecting an effective location for the ISO-MAX isolator. Existing system switches and gain controls can provide very important clues about just where noise is entering the signal path. ***If interrupting the signal path stops the noise, the noise must be entering the signal path at a point upstream of the interruption.***

For example, if the noise is present only when a specific signal source is selected, the noise entry point is likely upstream, i.e. somewhere between that source and the device which contains the selector. Likewise, if the noise is present with any input selected, the noise entry point is likely downstream, i.e. somewhere between the device which contains the selector and the speaker (or other monitoring point). Generally, working "backward" (from the speaker toward the signal source) through the system is the fastest way to determine which parts of the system are noise-free.

Obviously, the signal path can also be interrupted by selectively disconnecting signal cables between pieces of equipment. **Important note:** *if a "ground loop" does exist between two pieces of equipment, it will not be broken until all cables which directly connect them are disconnected.*

If the above tests are inconclusive, there may be a defect with one or more pieces of equipment. An insidious design defect called the "pin 1 problem" is very common. Since it effectively turns the equipment's input and/or output shield connections into audio inputs, it can be revealed through a simple test: with the signal path interrupted (see note in previous paragraph), temporarily connect only the shield contact (pin 1 for XLRs) of the cable to the shield contact of the suspected input or output using a jumper wire. If this connection causes hum or buzz, you have a "pin 1 problem." See the "Setting the Grounding Option Switches" for proper settings to overcome this problem.

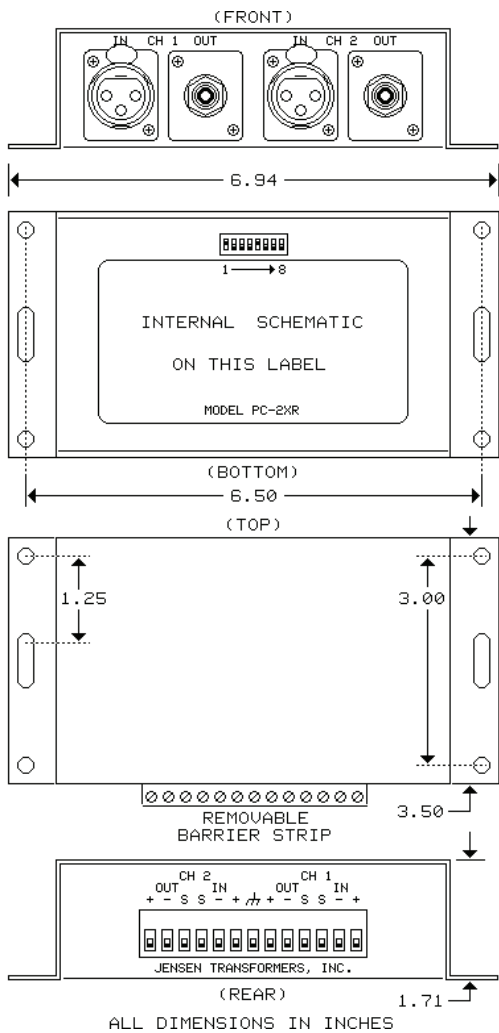

Setting the Grounding Option Switches

The settings of the 8 DIP switches on the bottom of the unit determine if and how input and output shields are connected to the case, denoted \nearrow at the terminal strip, and to each other. Switches 1 through 4 apply to Channel 1 and switches 5 through 8 apply to Channel 2.

Normally, the shield of any balanced audio cable should always be solidly grounded at the “send” (source) end. At the “receive” (load) end, there are disadvantages to both solidly grounding the shield and leaving it disconnected (floating). An RF damping network, which effectively disconnects the shield at audio frequencies but grounds it at RF frequencies, usually offers the best overall performance.

This configuration is achieved by the “as shipped” settings as shown in the drawings. These settings, switches 2 and 6 “off” (open) and all others “on” (closed), will give the best results in most systems.

If a “pin 1” problem exists at the output of the signal source equipment, it can usually be eliminated by opening S1 and/or S5.

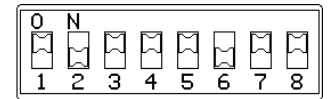

About “Floating” Equipment

Equipment which has a 2-prong power cord and has no other ground connections through other signal cables may “float” at a relatively high voltage (approaching line voltage, but harmless because of the limited “leakage” current) above the ground voltage reference for the remainder of the system. If the output of the PC-2XR drives such equipment, hum may still be a problem because of the high common-mode voltage.

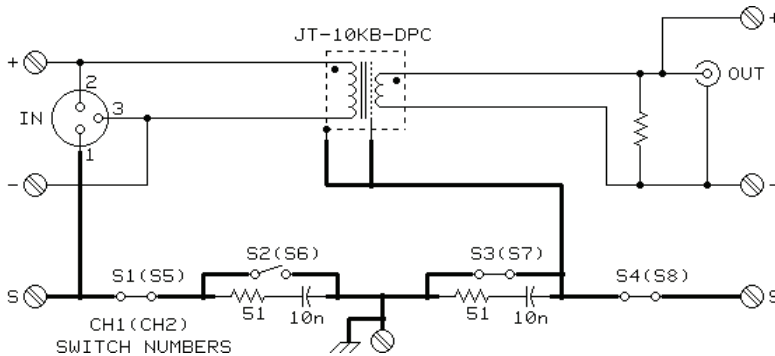

In these cases, it will be necessary to connect a wire (gauge unimportant) between the case, denoted \nearrow at the terminal strip, and the chassis of the piece of equipment which the output drives and close S2 and S6. This reduces the voltage between the “floating” equipment and the driving equipment without passing the small AC line current through the shield of the output RCA cable, which would produce hum. If the PC-2XR is connected via rack mounting to the equipment being driven, this is unnecessary.

If You Need Help

If you experience difficulty or have technical questions, our staff engineers are available from 9 AM to 5 PM Pacific time, Monday through Thursday, by calling (818) 374-5857. You may also reach us by FAX 24 hours a day, 7 days a week at (818) 374-5856 or e-mail us at info@jensen-transformers.com.

Several Jensen application notes discuss the technical aspects of grounding and interfacing in audio and video systems. They are available free on request. This information, as well as data on our full line of products for audio and video, may be obtained from our website at www.jensen-transformers.com.

ISO-MAX[®] PRODUCT WARRANTY

For a period of 1 YEAR after purchase, Jensen Transformers, Inc. will, free of charge, repair or replace any part of an ISO-MAX[®] product that fails due to defective materials or workmanship.

For a period of 20 YEARS after purchase, Jensen Transformers, Inc. will, free of charge, repair or replace any Jensen OEM transformer or any Jensen transformer contained in an ISO-MAX[®] product that fails due to defective materials or workmanship.

Both limited warranties are subject to the following limitations:

- 1) Defects that are, in the sole judgement of Jensen, the result of accident, misuse, abuse, neglect, mishandling, misapplication, faulty installation, unauthorized repair, modification, or acts of God will not be covered by this warranty.
- 2) In the absence of proof of date of purchase, the date of manufacture (as determined from lot numbers of internal parts and the records of Jensen Transformers, Inc.) shall be used in its place.
- 3) There are no express warranties except as listed above.
- 4) JENSEN TRANSFORMERS, INC. SHALL NOT BE LIABLE FOR INCIDENTAL OR CONSEQUENTIAL DAMAGES RESULTING FROM THE USE OF THIS PRODUCT OR ARISING OUT OF THE BREACH OF THIS WARRANTY. Duration of implied warranties, if any, is limited to 12 months. If a problem develops with this product during the warranty period, call or write us before attempting any repair. We can help you identify specific problems, and possibly solve the problem, before the unit is returned to us for repair or replacement. In any case, DO NOT RETURN THE UNIT WITHOUT AUTHORIZATION and instructions from us. Jensen cannot be responsible for damage due to shipping or improper packaging.

Limitations of Liability

The information provided by Jensen about its products been checked and is believed to be accurate; however, no responsibility is assumed by Jensen for its use nor for any infringements of patents which may result from its use. No license is granted by implication or otherwise under any patent or patent right of Jensen Transformers, Inc.

JENSEN PRODUCTS ARE NOT AUTHORIZED FOR USE AS CRITICAL COMPONENTS IN LIFE SUPPORT DEVICES OR SYSTEMS, OR IN ANY APPLICATION WHERE THEIR FAILURE COULD CAUSE INJURY OR DEATH.

Jensen reserves the right to make changes without further notice to any of its products. Jensen makes no warranty, representation or guarantee regarding the suitability of any of its products for any particular purpose, nor does Jensen assume any liability arising out of the application or use of any product or circuit, and specifically disclaims any and all liability, including without limitation consequential or incidental damages.