

Microphone Input Transformer

1:1 FOR ULTRA-LOW NOISE AMPLIFIERS

- Ideal retrofit to solve problems with transformerless preamps
- Dual Faraday shields provide very high CMRR: 122 dB at 60 Hz
- Eliminates complex circuitry required to block 'phantom' power
- Excellent frequency response and time domain performance
- Low transformer related Noise Figure

This transformer is designed to couple a nominal 150 Ω mic to the 3 kΩ input impedance typical of 'transformerless' preamps. Both windings are fully balanced and either may be reversed to invert polarity. A 30 dB magnetic shield package is standard. Not recommended for mic 'splitter' applications (use JT-MB-C).

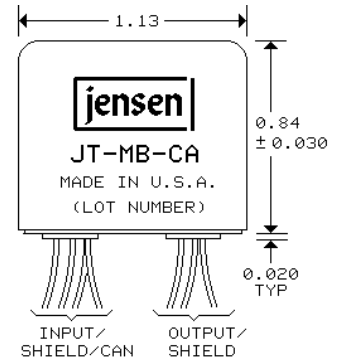

#30 AWG (7x38) UL STYLE 1061 COLOR CODED WIRE LEADS, 8" MINIMUM LENGTH

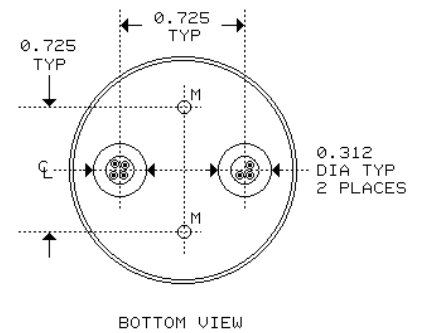
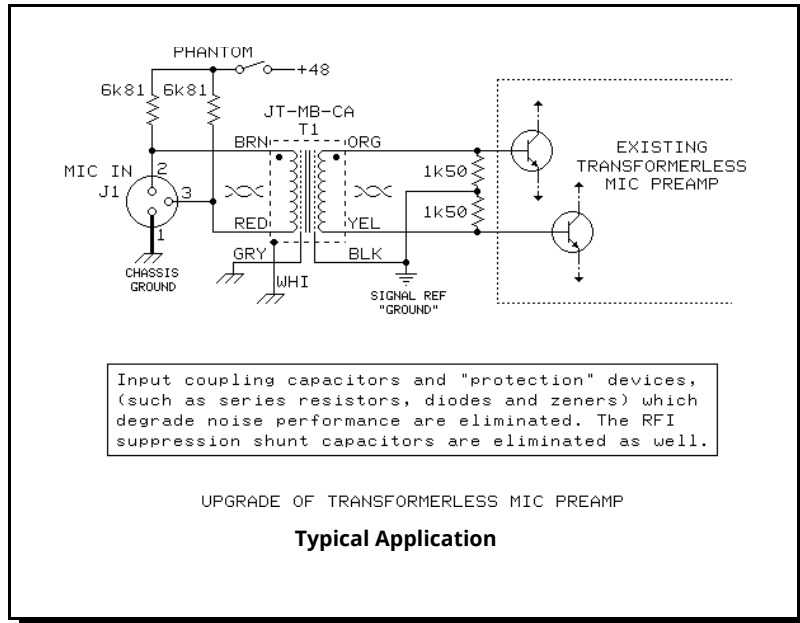

USE ONLY #4 TYPE B SELF TAPPING SCREWS IN HOLES "M". ALLOW NO MORE THAN 0.15" PENETRATION INTO TRANSFORMER HOUSING.

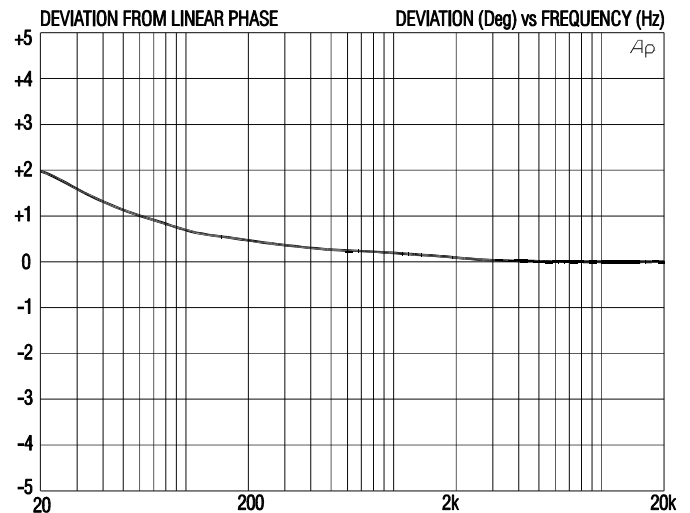
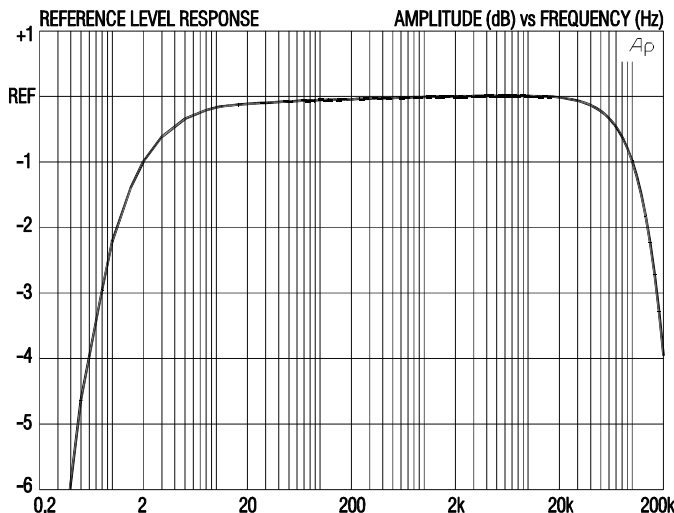

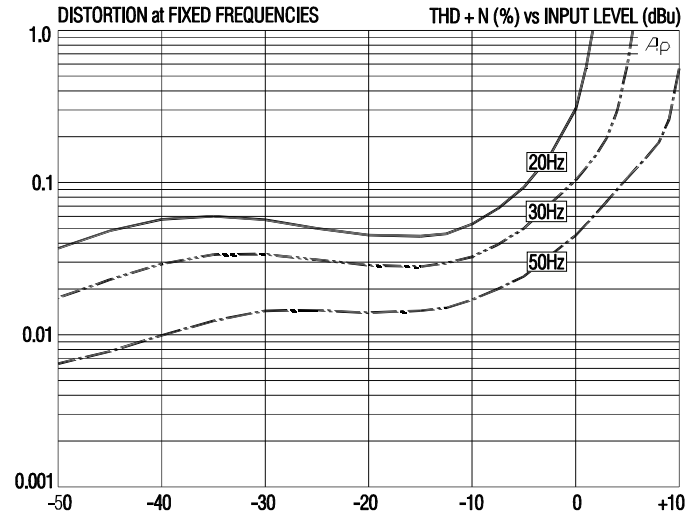
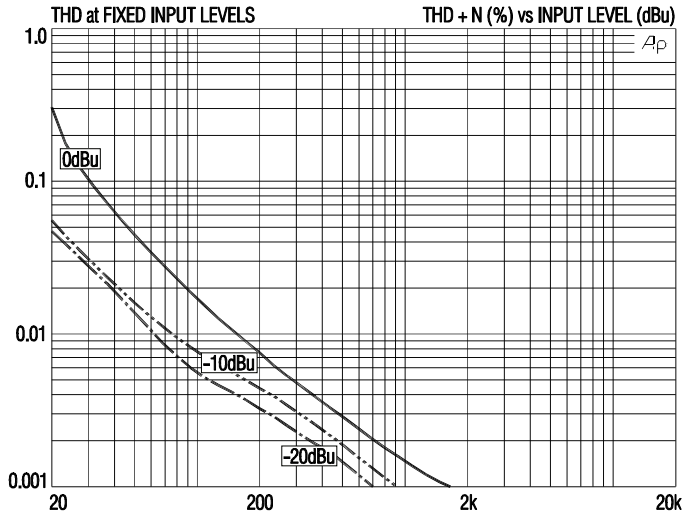

JT-MB-CA SPECIFICATIONS (all levels are input unless noted)

PARAMETER	CONDITIONS	MINIMUM	TYPICAL	MAXIMUM
Input impedance, Z_i	1 kHz, -20 dBu, test circuit 1	2.8 k Ω	2.9 k Ω	3.0 k Ω
Voltage gain	1 kHz, -20 dBu, test circuit 1	-0.2 dB	-0.26 dB	-0.3 dB
Magnitude response, ref 1 kHz	20 Hz, -20 dBu, test circuit 1	-0.2 dB	-0.1 dB	± 0.0 dB
	20 kHz, -20 dBu, test circuit 1	-0.1 dB	-0.04 dB	+0.1 dB
Deviation from linear phase (DLP)	20 Hz to 20 kHz, -20 dBu, test circuit 1		+2.0°	$\pm 3.0^\circ$
Distortion (THD)	1 kHz, -20 dBu, test circuit 1		<0.001%	
	20 Hz, -20 dBu, test circuit 1		0.045%	0.15%
Maximum 20 Hz input level	1% THD, test circuit 1	0 dBu	+2.0 dBu	
Common-mode rejection ratio (CMRR) 150 Ω balanced source	60 Hz, test circuit 2		122 dB	
	3 kHz, test circuit 2	80 dB	89 dB	
Common-mode rejection ratio (CMRR) 150 Ω unbalanced source	60 Hz, test circuit 3		111 dB	
	3 kHz, test circuit 3		78 dB	
Output impedance, Z_o	1 kHz, test circuit 1		223 Ω	
DC resistances	primary (BRN to RED)		46.4 Ω	
	secondary (ORG to YEL)		46.2 Ω	
Capacitances @ 1 kHz	primary to shield (GRY) and case (WHI)		46 pF	
	secondary to shield (BLK) and case (WHI)		62 pF	
Turns ratio		1:0.999	1:1.000	1:1.001
Temperature range	operation or storage	0° C		70° C
Breakdown voltage (see IMPORTANT NOTE below)	primary or secondary to shield and case, 60 Hz, 1 minute test duration	250 V RMS		

IMPORTANT NOTE: This device is NOT intended for use in life support systems or any application where its failure could cause injury or death. The breakdown voltage specification is intended to insure integrity of internal insulation systems; continuous operation at these voltages is NOT recommended. Consult our applications engineering department if you have special requirements.

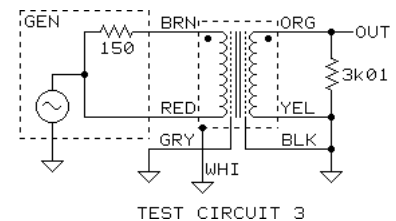
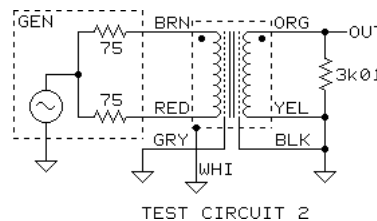
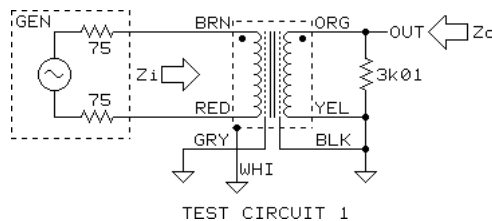

All minimum and maximum specifications are guaranteed. Unless noted otherwise, all specifications apply at 25°C. Specifications subject to change without notice. All information herein is believed to be accurate and reliable, however no responsibility is assumed for its use nor for any infringements of patents which may result from its use. No license is granted by implication or otherwise under any patent or patent rights of Jensen Transformers, Inc.