

## Moving Coil Transformer

1:12 STEP-UP FOR MC CARTRIDGES UP TO 5 Ω

- Our highest performance moving coil input transformer
- Wide bandwidth: -3 dB at 0.3 Hz and 200 kHz
- Excellent time domain performance: DLP +1° typical
- Transformer Noise Figure only 1.4 dB @ 5 Ω, 2.1 dB @ 3 Ω
- High common-mode rejection: 145 dB at 60 Hz

This transformer, with about 750 Ω secondary source impedance, will give excellent noise performance with ultra-low  $e_n$  amplifiers. The primary is fully balanced and its leads may be reversed to invert polarity. 60 dB nested double magnetic shielding is standard. See companion data sheet for 25 Ω or 40 Ω use.

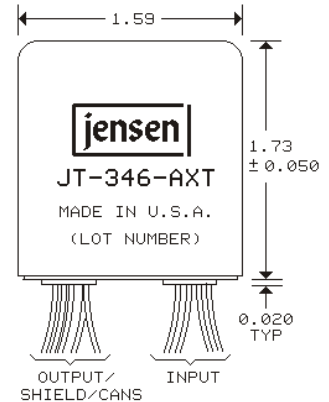

8 INCH #26 AWG (7x34) SILVER PLATED COPPER LEADS WITH TEFLON INSULATION

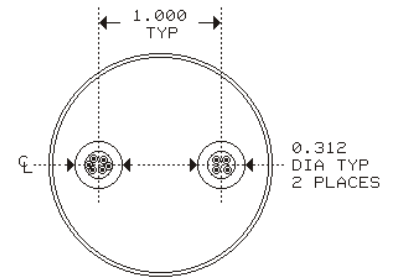
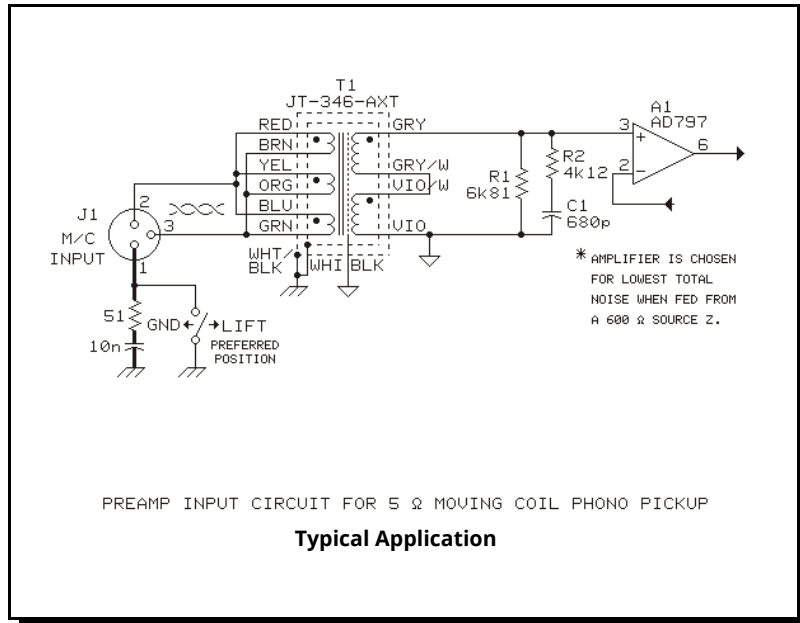

BOTTOM VIEW

RECOMMENDED MOUNTING IS WITH UR-4 CLAMP (SUPPLIED WITH TRANSFORMER)

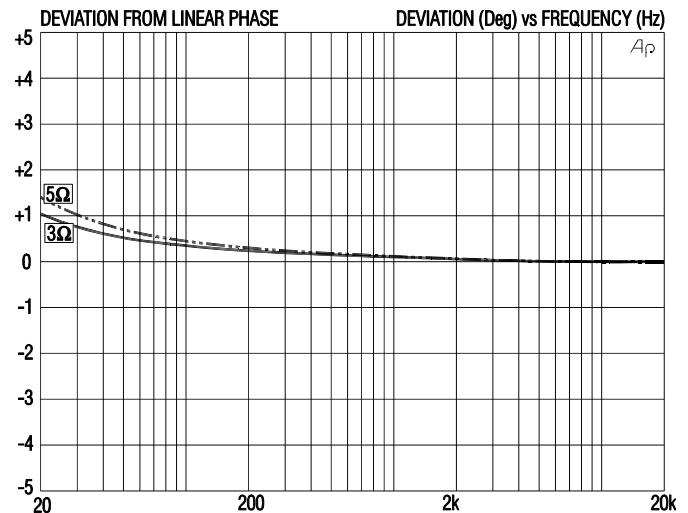
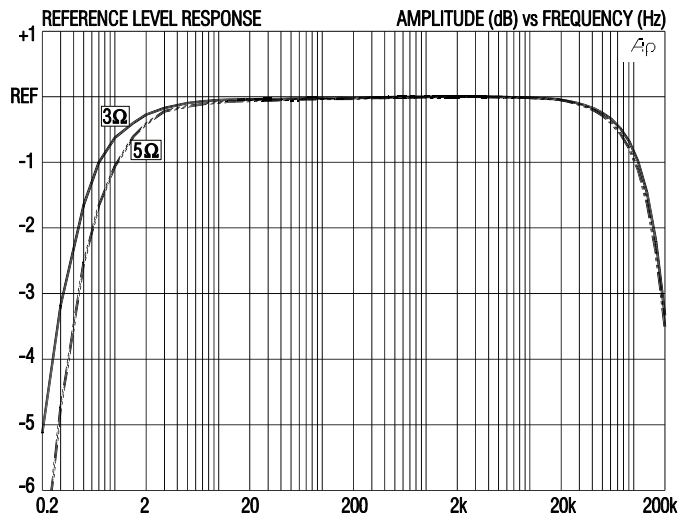

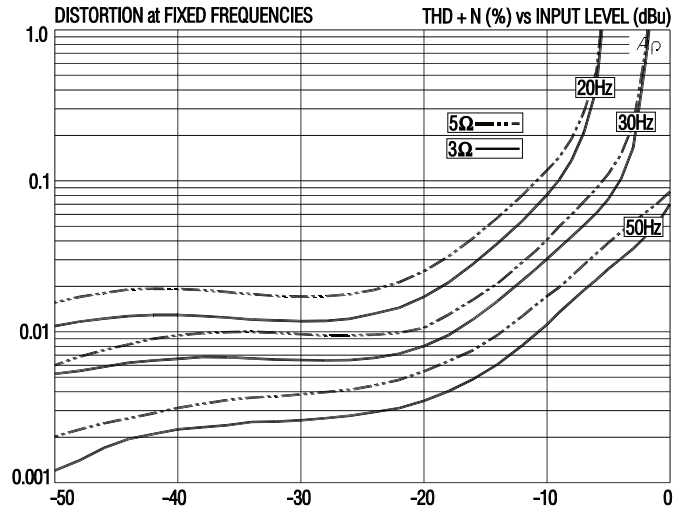
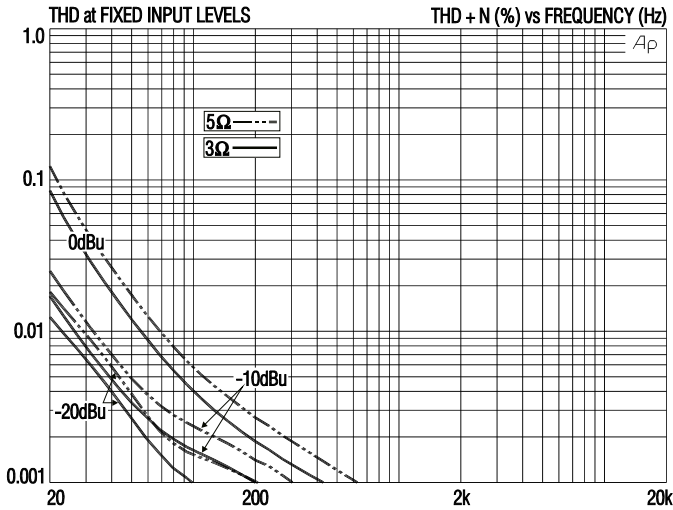

**JT-346-AXT SPECIFICATIONS** (unless noted, apply for either 3 Ω or 5 Ω sources; all levels are input)

PARAMETER	CONDITIONS	MINIMUM	TYPICAL	MAXIMUM
Input impedance, Zi	1 kHz, -40 dBu, test circuit 1	44.0 Ω	46.3 Ω	48.5 Ω
Voltage gain	1 kHz, -40 dBu, test circuit 1	21.35 dB	21.45 dB	21.55 dB
Magnitude response, ref 1 kHz	20 Hz, -40 dBu, test circuit 1	-0.1 dB	-0.05 dB	±0.0 dB
	20 kHz, -40 dBu, test circuit 1	-0.1 dB	-0.03 dB	+0.1 dB
Deviation from linear phase (DLP)	20 Hz to 20 kHz, -40 dBu, test circuit 1		+1.2°	±2°
Distortion (THD)	1 kHz, -40 dBu, test circuit 1		<0.001%	
	20 Hz, -40 dBu, test circuit 1		0.015%	0.05%
Maximum 20 Hz input level	1% THD, test circuit 1	-7.0 dBu	-5.4 dBu	
Common-mode rejection ratio (CMRR)	60 Hz, test circuit 2		145 dB	
	3 kHz, test circuit 2	100 dB	115 dB	
Output impedance, Zo	1 kHz, Rs = 3 Ω, test circuit 1		633 Ω	
	1 kHz, Rs = 5 Ω, test circuit 1		870 Ω	
DC resistances	3 primaries in parallel (per test circuits)		0.643 Ω	
	2 secondaries in series (GRY to VIO)		154 Ω	
Capacitances @ 1 kHz	3 primaries in parallel to shield and case		573 pF	
	2 secondaries in series to shield and case		417 pF	
Turns ratio	3 primaries in parallel (per test circuits)	1:12.200	1:12.224	1:12.250
Temperature range	operation or storage	0° C		70° C
Breakdown voltage (see IMPORTANT NOTE below)	primary or secondary to shield and case, 60 Hz, 1 minute test duration	250 V RMS		

**IMPORTANT NOTE:** This device is NOT intended for use in life support systems or any application where its failure could cause injury or death. The breakdown voltage specification is intended to insure integrity of internal insulation systems; continuous operation at these voltages is NOT recommended. Consult our applications engineering department if you have special requirements.

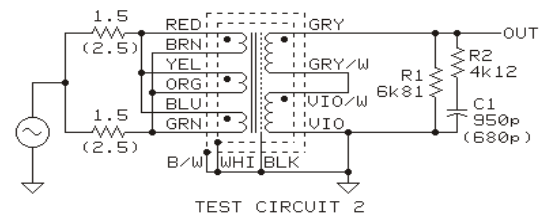
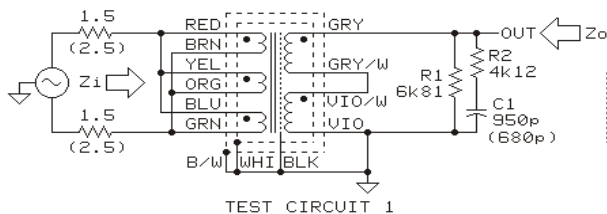

All minimum and maximum specifications are guaranteed. Unless noted otherwise, all specifications apply at 25°C. Specifications subject to change without notice. All information herein is believed to be accurate and reliable, however no responsibility is assumed for its use nor for any infringements of patents which may result from its use. No license is granted by implication or otherwise under any patent or patent rights of Jensen Transformers, Inc.