



Superior Magnetics Since 1979



CMOB-1

LINE OUTPUT TRANSFORMER Bifilar Windings

- Excellent bandwidth: -1.82 dB at 200 kHz,
- Rs=150Ω
- 80% Nickel (“HiNi”) or 50% Ni/50% Steel laminations
- Distortion $\leq 0.01\%$ typ at 20 Hz, Rs=150Ω HiNi
- +27 dBm at 20 Hz, 1% THD+N Rs $\leq 150\Omega$
- Phase Shift -2° at 20 kHz, Rs=150Ω
- Low insertion loss

The CineMag CMOB-1 output transformer uses bifilar construction techniques. This two winding transformer delivers good coupling between windings as well as excellent bandwidth. It is available both with 80% Nickel (“HiNi”) and 50% Nickel/50% Steel laminations. It can be driven with source impedances of up to 600Ω. As with all line driving devices, the amplifier feeding it should be capable of cleanly delivering the power required to reach maximum operating level.

CMOB-1H / CMOB-1L

Parameter	Conditions	Typ
Turns Ratio		1 : 1.00
Input Impedance, Zi	20 Hz to 20 kHz, 0 dBu Test Circuit 3	680Ω
Voltage Gain	1 kHz HiNi Core, Rs=150 1 kHz 50% Nickel/50% Steel Core, Rs=150	-2.8 dB -2.81 dB
Distortion (THD+N%)	1 kHz, +4 dBu, Rs=150 HiNi Test Circuit 1 1 kHz, +4 dBu, Rs=150 50%Ni/50% Steel	0.0003% 0.0005%
Max 20 Hz input level	1.0% THD+N, Rs ≤ 150 HiNi Test Circuit 1 1.0% THD+N, Rs ≤ 150 50% Ni 50% Steel	+27 dB +28 dB
Response, ref 1 kHz	20 Hz Rs=150Ω HiNi Test Circuit 1 20 kHz Rs=150Ω HiNi Test Circuit 1 200 kHz Rs=150Ω Test Circuit 1	-0.01 dB +0.01 dB -1.82 dB
Phase Shift at 20Hz Phase Shift at 20 kHz	Referenced to source generator Test Circuit 1	+0.5° -2°
CMRR	60 Hz Test Circuit 4 per IEEE Std 389-1996 ¶19 1 kHz Test Circuit 4 per IEEE Std 389-1996 ¶19	85 dB 84dB
Output CMRR	60 Hz Test Circuit 2 1 kHz Test Circuit 2	92 dB 86 dB
Operating Temp Range	Operation and storage	0° C Min 70° C Max

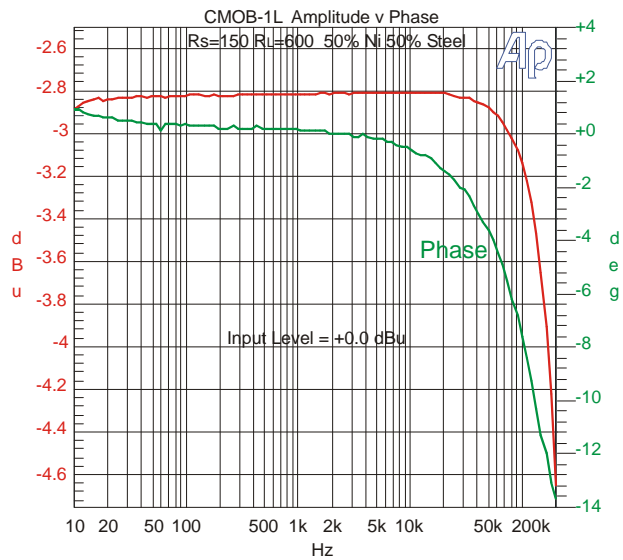
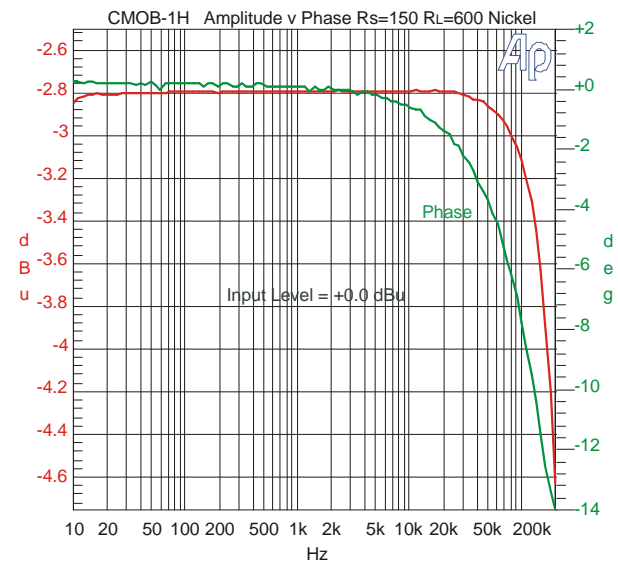
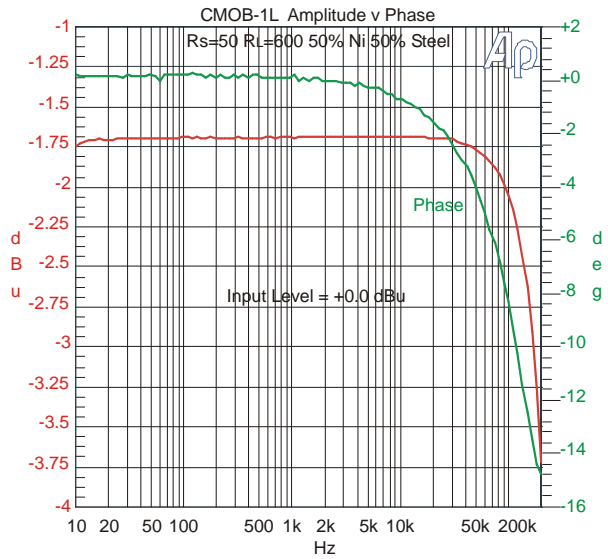
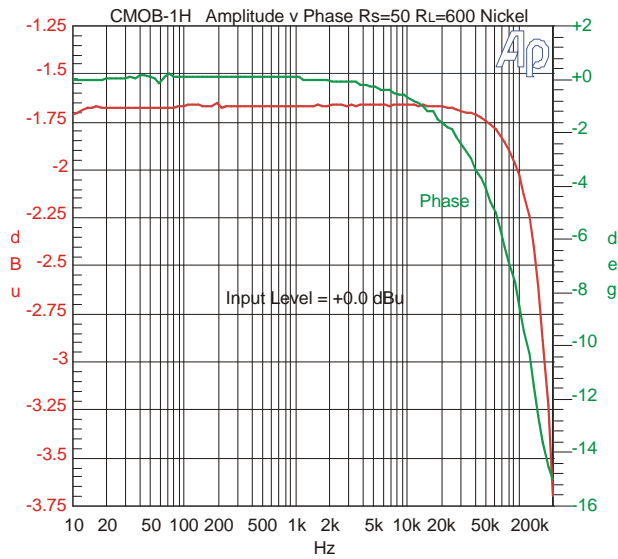
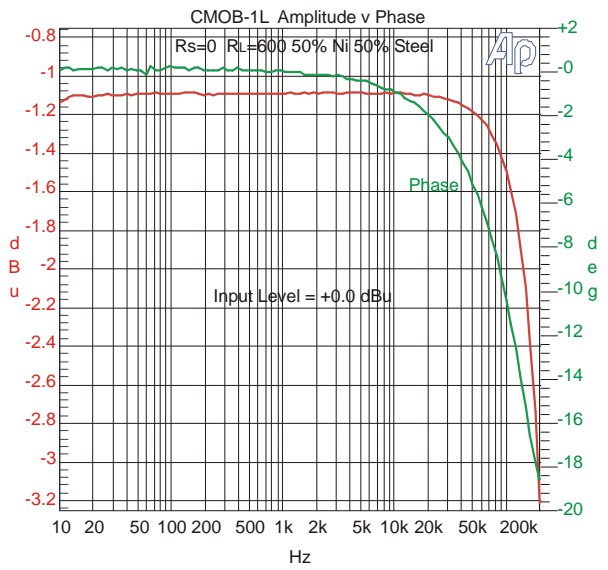
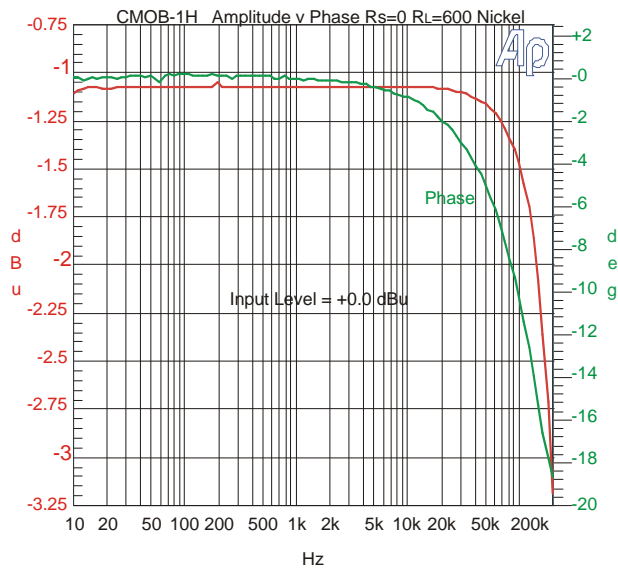

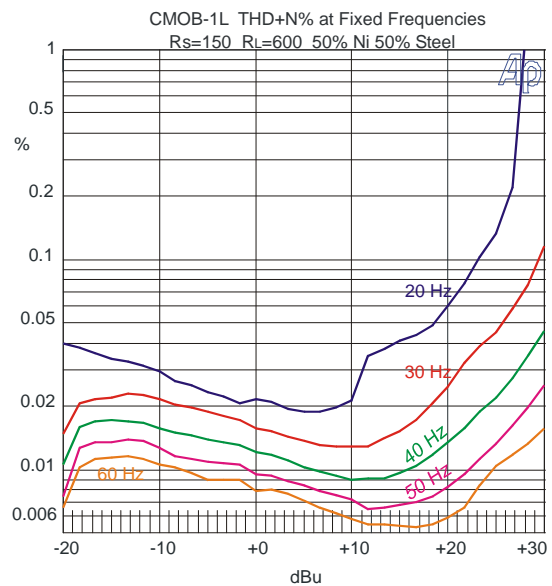
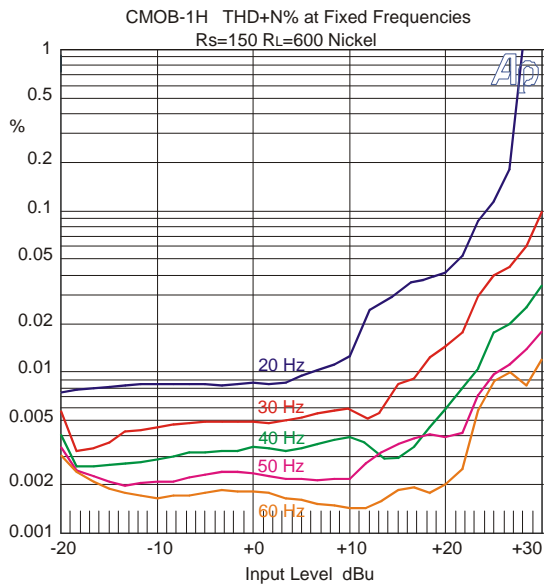
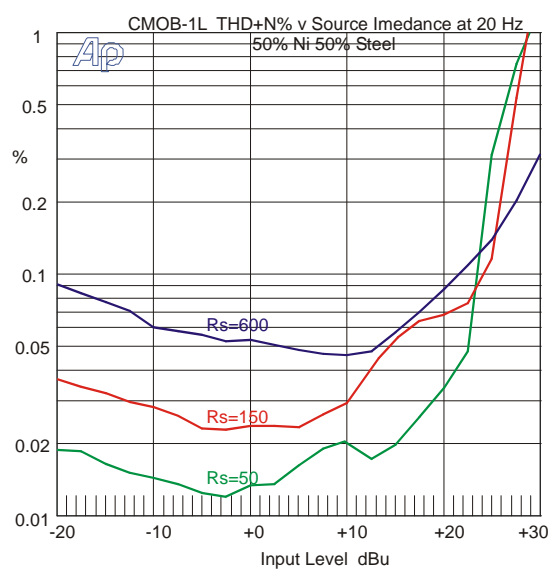
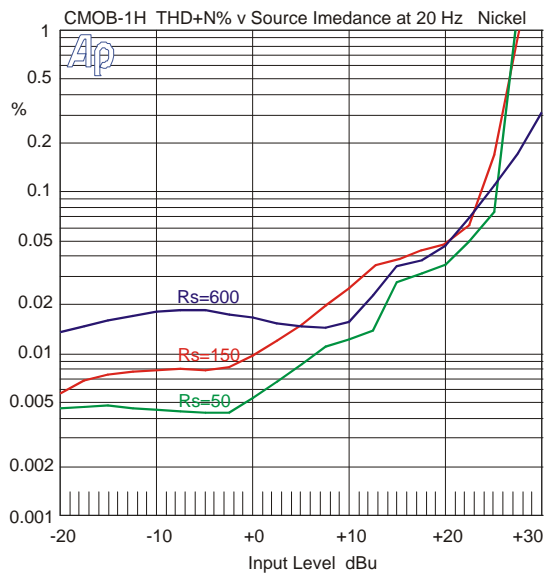
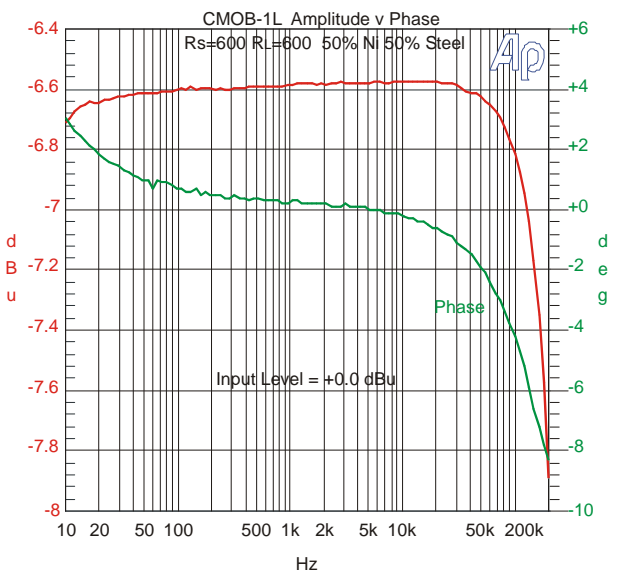
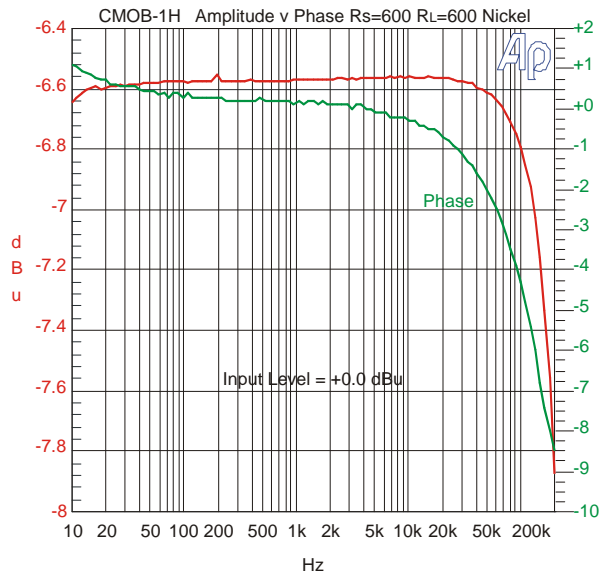

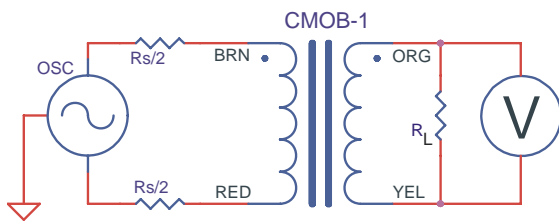
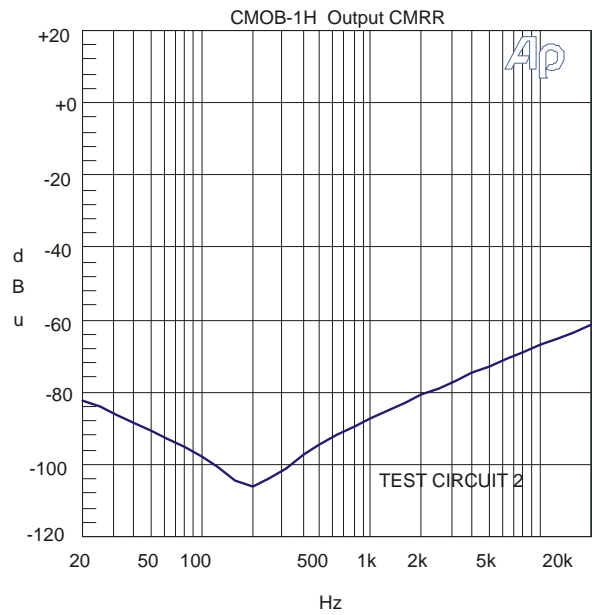
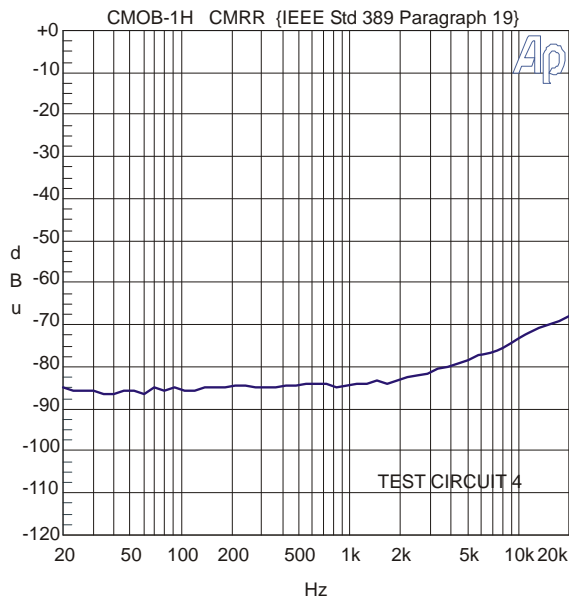
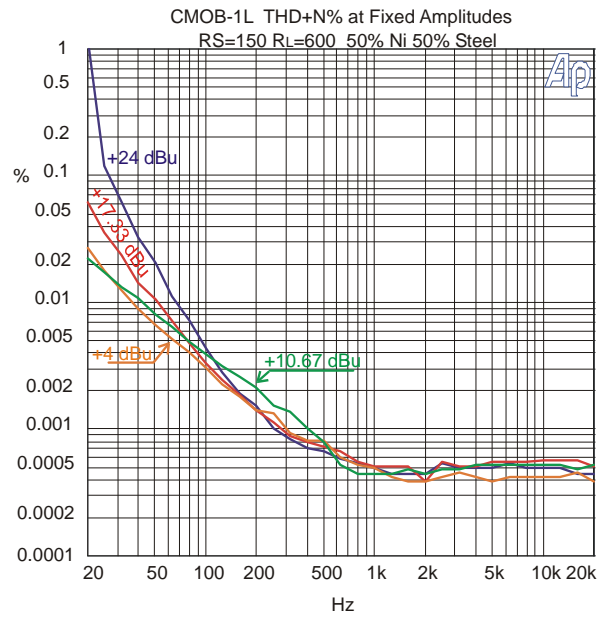
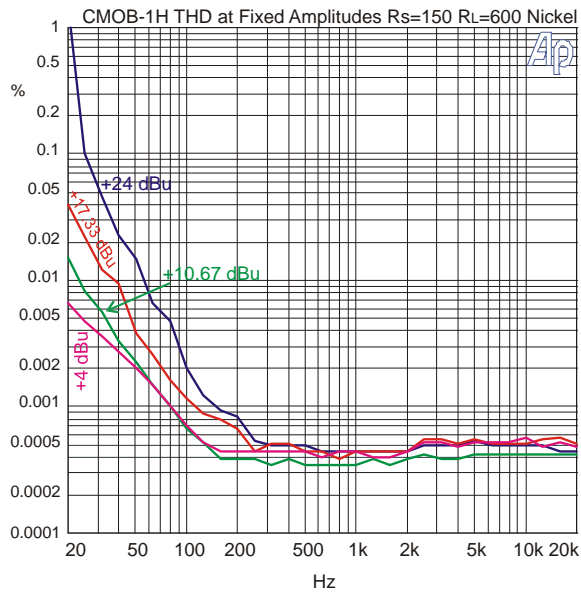

TEST CIRCUIT 1

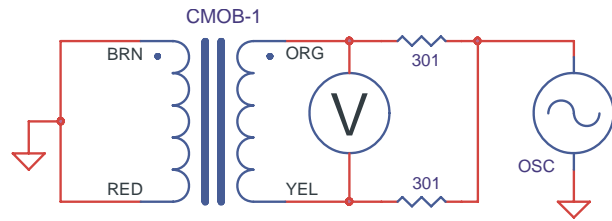

TEST CIRCUIT 2

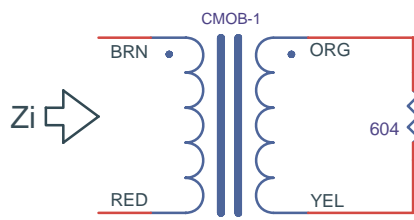

TEST CIRCUIT 3

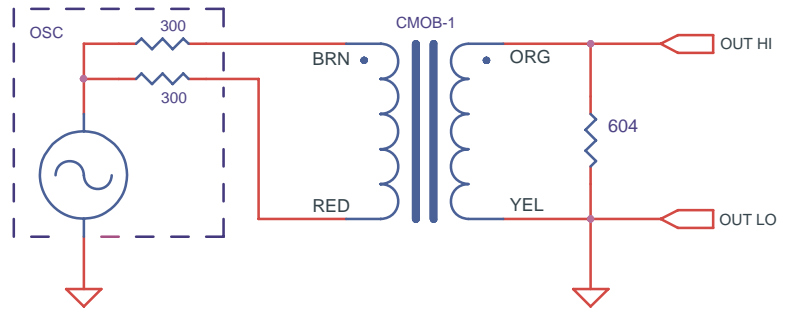

TEST CIRCUIT 4

NOTES:

1. All graphs generated from one (1) randomly chosen device. No statistical averaging or weighting. Data from one sweep.
2. $R_L = 604$ unless otherwise noted.

