



Superior Magnetics Since 1979



CMMI-10B

Microphone Input Transformer 1 : 10 Step-up

- Use with high input impedance amplifiers (i.e. J-FET and Tube)
- Good bandwidth (- 3 dB at 95 kHz)
- Good CMRR: 95 dB at 60 Hz
- +19.75 dB step-up; 1 : 10 turns ratio
- Low profile package
- P.C. mount and lead packages

The CineMag CMMI-10B is one of the most commonly used commercial grade microphone input transformers produced by CineMag Inc.. It is designed for high input impedance amplifiers. It exhibits good bandwidth, common mode rejection ratio (CMRR), and distortion characteristics. The CMMI-10B is available with either wire leads or p.c. mount package. It is widely used in professional grade designs. It is encased in a μ Metal can which provides 30 dB of magnetic shielding. All the wires connecting the internal foil shields between windings are spot welded for maximum long term reliability, as is done with all CineMag transformers.

This transformer has a high impedance secondary. Care must be exercised in the design of the amplifier that it feeds to obtain best results and to realize best bandwidth.

CMMI-10B / CMMI-10B-PC

Parameter	Conditions	Typ
Turns Ratio		1 : 10.00
Voltage Gain	1 kHz, -20 dBu 150 Ω input, 150K secondary load impedance	19.75 dB
Distortion (THD+N%)	1 kHz, -11 dBu Test Circuit 1 20 Hz, -20 dBu Test Circuit 1	0.0015% 0.065%
Max 20 Hz input level	1.0% THD; 150 Ω input, 150K secondary load impedance Test Circuit 1	-1 dBu
Response, ref 1 kHz	20 Hz Test Circuit 1 20 kHz Test Circuit 1 -3 dB	-0.25 dB +0.025 dB 115 kHz
Phase Shift at 20 Hz Phase Shift at 20 kHz	Referenced to source generator Test Circuit 1	+4° -10°
CMRR	60 Hz Test Circuit 2 per IEEE Std 389-1996 ¶19 1 kHz Test Circuit 2 per IEEE Std 389-1996 ¶19	95 dB 72 dB
Operating Temp Range	Operation and storage	0° C Min 70° C Max
Max Soldering Temp.	5 Seconds	335° C Max

9050 Independence Ave. Canoga Park, California 91304
<http://www.cinemag.org/>

☎(818) 993-4644 ☒ (818) 993-4604

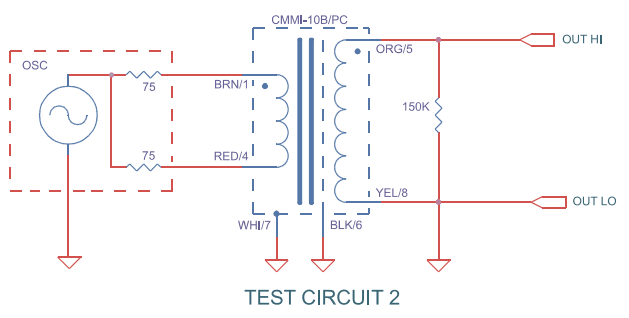
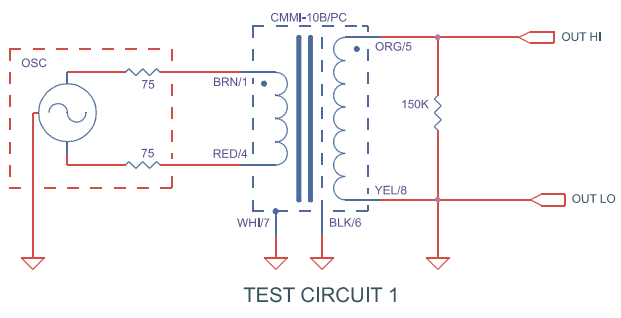
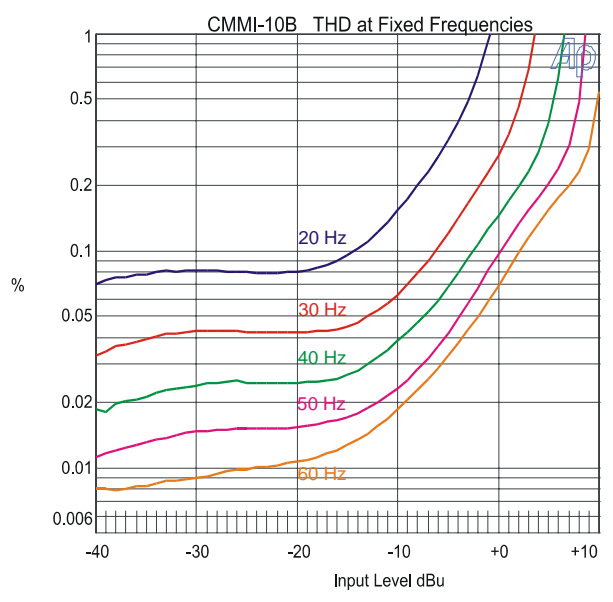
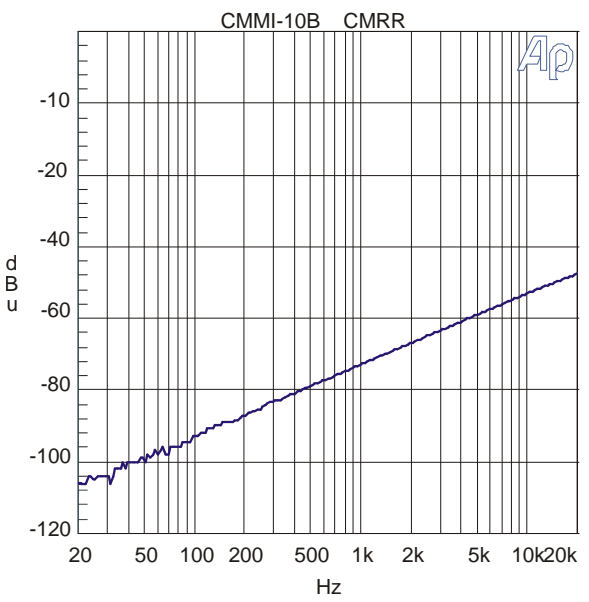
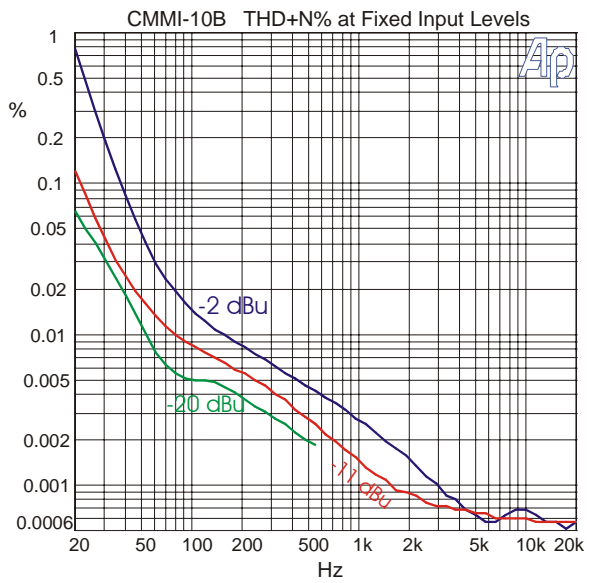
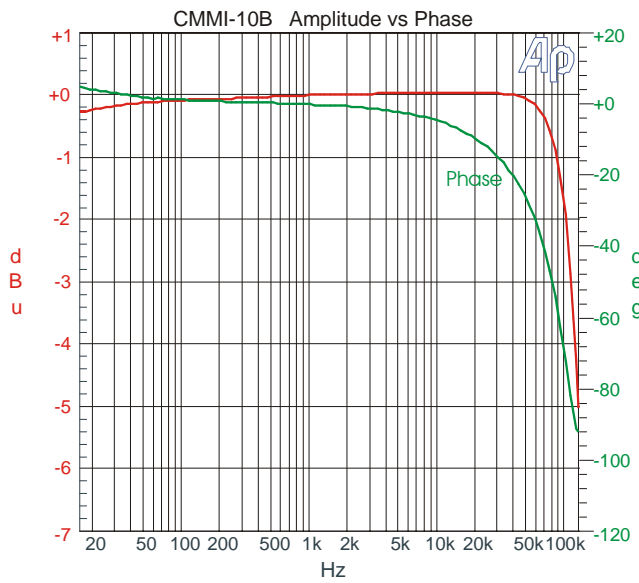

NOTES: 1. All graphs generated from one (1) randomly chosen device. No statistical averaging or weighting. Data from one sweep.

