

How to Install and Use the 9870 Series Residential Category 5 HDTV Distribution System

Overview

The 9870 Series allows HDTV signals to be distributed throughout the home from a single source. Component video (YPbPr), analog stereo audio, and digital audio (coaxial) can be included in each two-cable Cat 5 pathway. By connecting IR remote control systems to the 9870 system, users can easily control the source equipment from other rooms in the house. IR receiver and emitter products are not included with the 9870 Series.

System Design

The 9870 Series is comprised of the Model 9871 RCA-to-Category 5 Driver and the Model 9878 Wallplate. These products enable distribution of audio, video and IR control signals on Cat 5 cable runs of up to 1,000 feet. The buffered Cat 5 bus outputs on each 9871 drive one or two 9878 Wallplates. To expand output capacity of the system, connect together an unlimited number of Drivers using Kit 46 (or high quality RCA patch cables). The 9878 offers a Wallplate format to fit a standard two-gang electrical box. DC power for each Wallplate is supplied through the Cat 5 cable from the 9871's power supply.

In addition to the Cat 5 outputs, the 9871 RCA bus output may be used as a pass-through output for a nearby HDTV or home theater (see below). **CAUTION:** never leave unterminated cables connected to 9871 RCA bus output. If you disconnect the receiver and TV, disconnect the cables from the 9871 at the same time, or the signal quality will be severely affected.

Rough-In

Wallplates are normally placed on the wall behind the television sets or entertainment centers remoted off the main home entertainment system. Set a two-gang plaster ring at each Wallplate location. Pull two runs of good quality Category 5, 5e or 6 UTP cable from the head-end location to each Wallplate location. Be careful not to pinch, kink, or tightly staple the cable. Mark both ends of the cables in each set A and B, or use two different jacket colors of UTP cable for A and B. It will be helpful to mark the cable length of each run at the Wallplate end because you will have to adjust the cable length compensation when installing each 9878.

Installing the 9871 Driver

Mount the (first) 9871 module to any flat vertical or horizontal surface using the screws provided. You may wish to leave space to add 9871 modules to expand output capacity. Connect component video and all audio connections desired from the source equipment to the inputs of the 9871. Use high quality, matched sets of component video cables, and high quality RCA cables for audio. The IR bus jacks are only used to connect 9871 modules together.

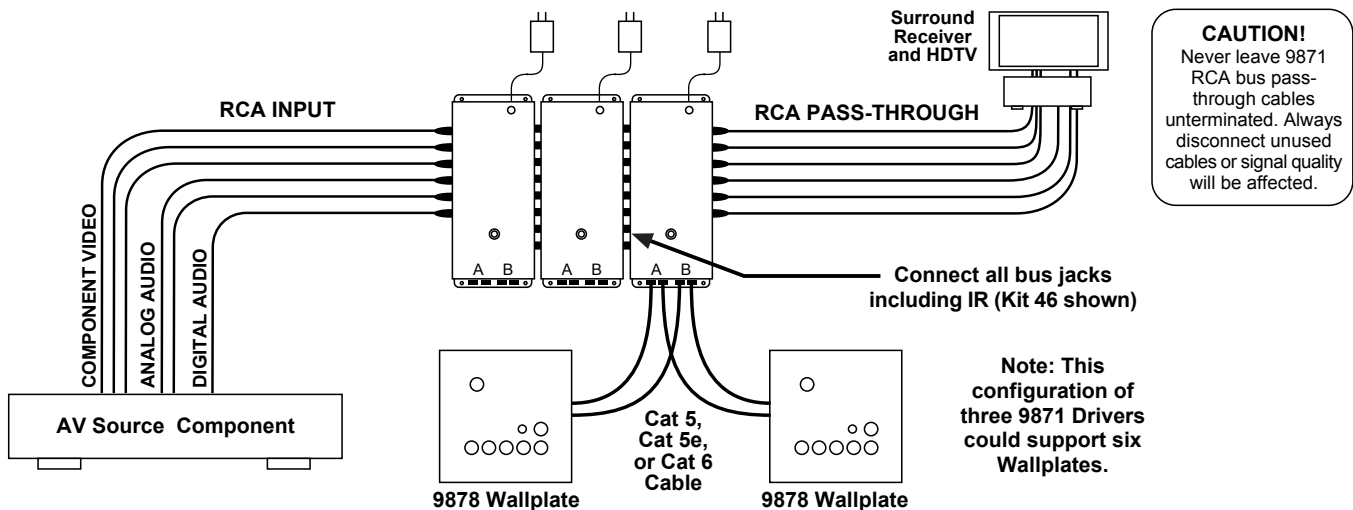

If installing more than one 9871 Driver, connect all the bus outputs of the first Driver to the inputs of the next Driver using high quality patch cables or Kit 46 (sold separately), which provides convenient male to male connectors for a more compact installation. Connect bus jacks for all channels whether or not they will be used.

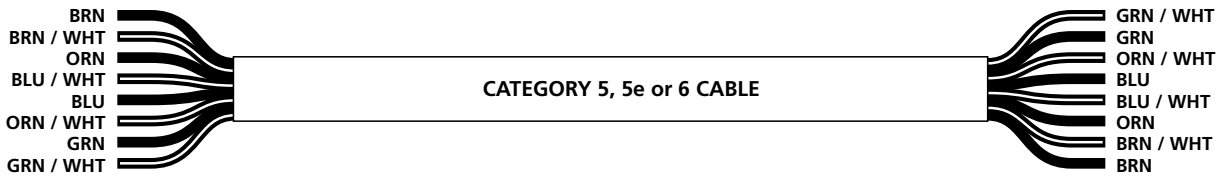

Install an RJ-45 plug on each end of every Cat 5 cable, using EIA-568 pairing (pins 1-2, 3-6, 4-5, 7-8). Check each cable with a network cable tester. Plug the Cat 5 cables into the A and B jacks on the Driver and Wallplates. Power source components, TVs, and AV receivers and plug in 9871 power supplies to test the system.

Installing 9878 Wallplates

Be sure to connect the A cable to the A jack and the B cable to the B jack. Adjust the cable length compensation if the cable between the Driver and the Wallplate is over 100 feet long. You may wish to connect the system to source equipment and a TV while adjusting the cable length compensation to verify optimal settings. Use the minimum compensation setting that still provides the best picture. A pass-through F-connector is provided in case antenna connection is desired (a separate coaxial cable must be pulled for antenna).

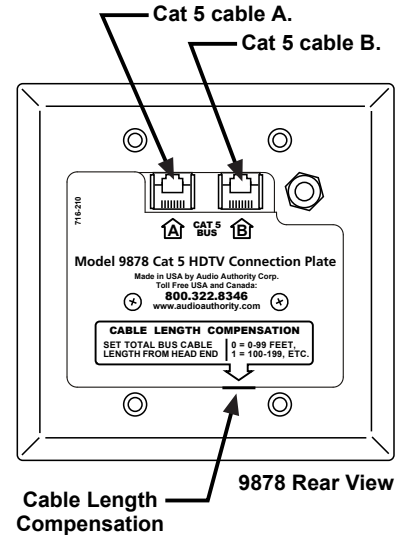

Connecting to an IR network

The 9870 system is not an IR remote control system; it only provides a Cat 5 pathway for a third party system. Connect an IR remote control system input to the IR output of a Driver (See example diagram below). Connect an IR receiver to each Wallplate and position them appropriately in the rooms. Do not connect any equipment to the white RCA jacks marked "IR".

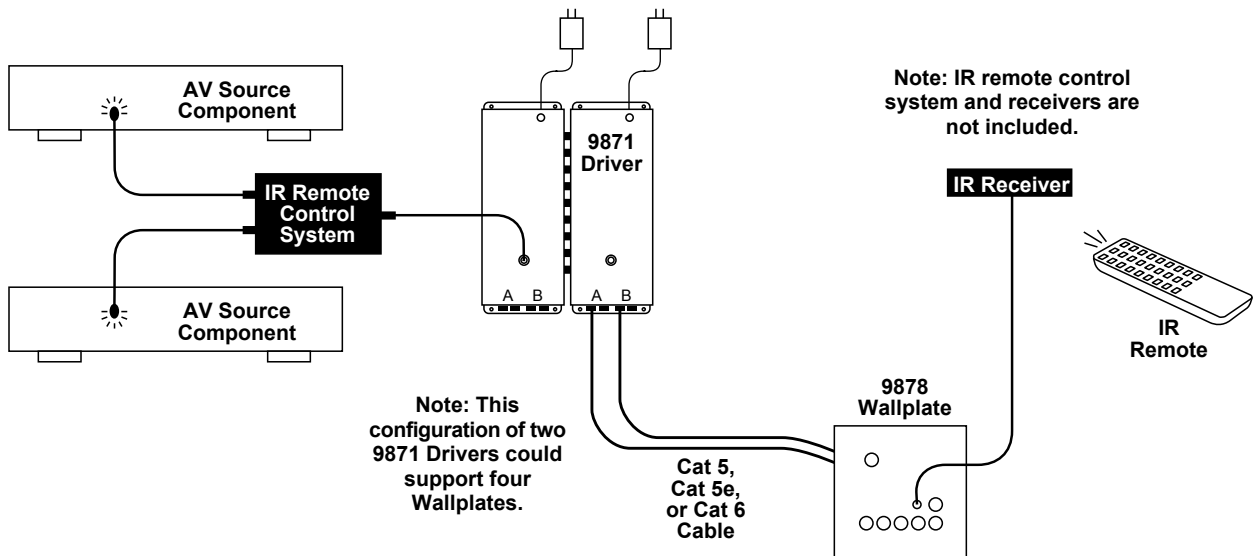

In Case of Difficulty

If any problems arise that are not covered in this manual, call Audio Authority Technical Support at 800.322.8346, or outside the US and Canada, call 859-233-4599.