

MOBO-T65

Motorized Flat Screen TV Tabletop Stand

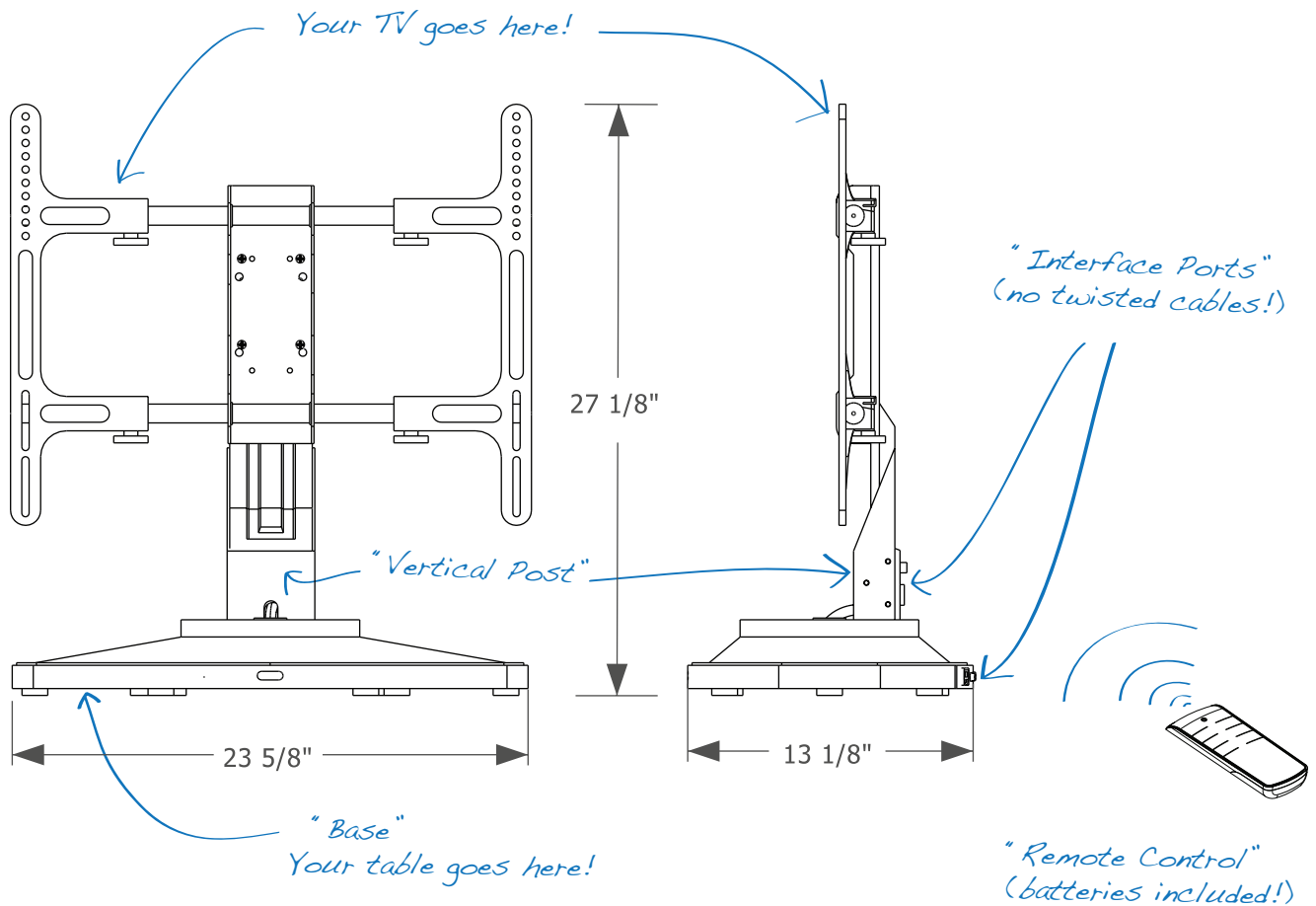





WARNING: Do NOT attempt to operate the unit until it has been installed in a proper position and the TV bracket assembly attached; attempting to operate the unit before full installation will damage the unit and void your warranty.



Parts:

Please make sure you have all parts before beginning installation. If any parts are missing or damaged, contact your retailer and DO NOT ATTEMPT INSTALLATION. Use only parts provided by the manufacturer or damage may result.

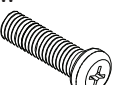
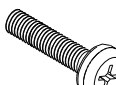
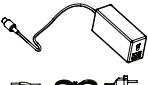
<p>① M6 x 10mm Bracket bolt 6 pcs</p> 	<p>② M6 x 15mm Bracket bolt 4 pcs</p> 	<p>③ Spacer 4 pcs</p> 	<p>④ Washer 4 pcs</p> 
<p>⑤ M6 x 25mm Television screw 4 pcs</p> 	<p>⑥ M5 x 25mm TV screw 4 pcs</p> 	<p>⑦ Power adapter 1 pc</p> 	

Tools:



A screwdriver is necessary for proper installation. If you don't own one already, you could borrow it from your neighbor. But if your neighbor is like ours, it's better to just go buy one.

SAFETY NOTICES

The television and stand are heavy and must be placed on a stable surface that is sturdy enough to easily support them both. It must also be placed so that it may rotate freely without obstruction. It should be positioned safely out of reach of children. If you are not familiar with how to properly prevent the stand from tipping, seek the advice of an expert. The manufacturer and retailer DO NOT assume any liability for improper installations or misuse. So if your television falls over, it is entirely your own problem.

DANGER!

This motorized bracket is an electrical device. This unit is designed for indoor use only. You should only use it in a dry and clean environment, and plugged into a properly grounded electrical outlet. If you die of electrocution, you will not be able to enjoy your television.

To reduce the risk of electrical shock you should take some basic precautions, including:

1. Always unplug the unit when installing, removing, mounting, adjusting, or cleaning the unit.
2. Never operate the unit outside of the limits, specifications or parameters described in this booklet.
3. Do not attach anything else to the bracket other than a television of the specified size/weight.
4. Do not attach any other accessories or devices, and do not let anyone touch the unit while in operation.
5. Never operate the system if it has become wet; if it shows any signs of damage; if it has become clogged with dust, lint or hair; shows signs of excessive wear and tear; or, if the power cords have become damaged or frayed.
6. Keep the unit and power cords away from heat sources such as vents, heaters, fireplaces, or radiators.
7. Use only a dry cloth to clean the unit; do not use any chemicals, sprays or liquids of any kind.
8. Periodically check to make sure all screws and fastening devices are properly tightened and secure. To avoid damage to the screw threads be sure not to over-tighten.

WARNING!!!

By attempting installation yourself, you assume all risks and consequences, so please be sure that you know what you're doing. If your spouse says, "Don't worry, I know what I'm doing," you should probably still worry. Incorrect installation can result in personal injury, damage to your television and other property.

The manufacturer and retailer are NOT responsible for improper installations.

The limited warranty only covers defects in the design or manufacture of the bracket, and doesn't cover issues arising from improper installation. If you are uncertain about how to safely install this unit, please seek help from a professional installer. These instructions are based upon a typical installation scenario; your particular circumstances may require the services of a custom installer.



Installation Instructions:

Step 1. Choose the Location

When considering the location for a tabletop stand, consider visual access and foot traffic. Find a location that is central for your open spaces, particularly locations that divide those spaces into smaller living areas for which television access is desired. Remember also that because the unit can rotate a total of 270 degrees, meaning it can face in opposite directions while still having some added adjustability at either end of the rotation range.

Be especially aware of hazards, such as being too close to the edge of a piece of furniture, which could let the television be easily bumped into by passers-by. Also consider the effects of wind, glare from sunlight streaming in through windows, and hazards to rotation such as curtains, fruit bowls, candlesticks, and bowling trophies, to name just a few. Careful planning will help to ensure the best outcome.



Carefully consider the location for your tabletop stand. You will want to choose a spot that gives you good visibility from all desired locations yet is also a secure and stable place, free from obstructions or hazards.

It's up to you to choose a location that is both useful and safe. The television and stand are heavy, but they can fall over if they are bumped, snagged, or standing on an unstable surface. So choose wisely!



Step 2. Attach the Vertical Post to the Base

Secure with the 6 locking screws (①) and tighten.

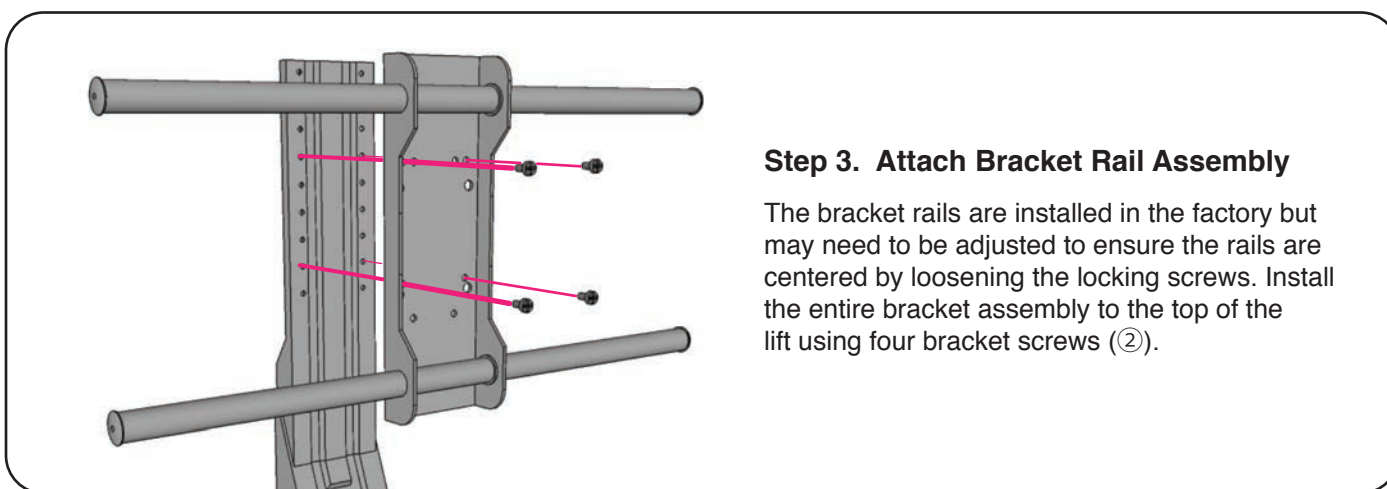
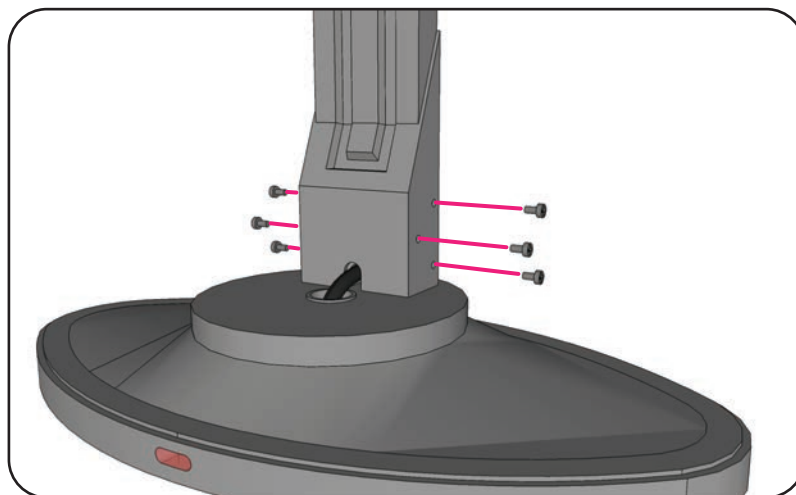
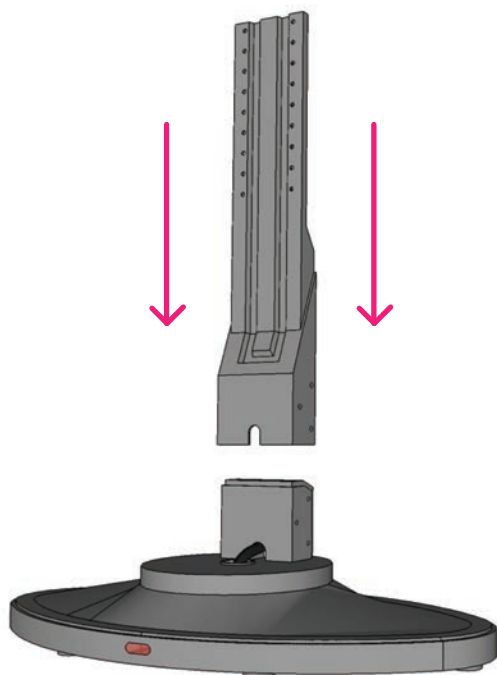

Step 3. Attach Bracket Rail Assembly

The bracket rails are installed in the factory but may need to be adjusted to ensure the rails are centered by loosening the locking screws. Install the entire bracket assembly to the top of the lift using four bracket screws (②).

Step 4. Attach Bracket Arms to Television

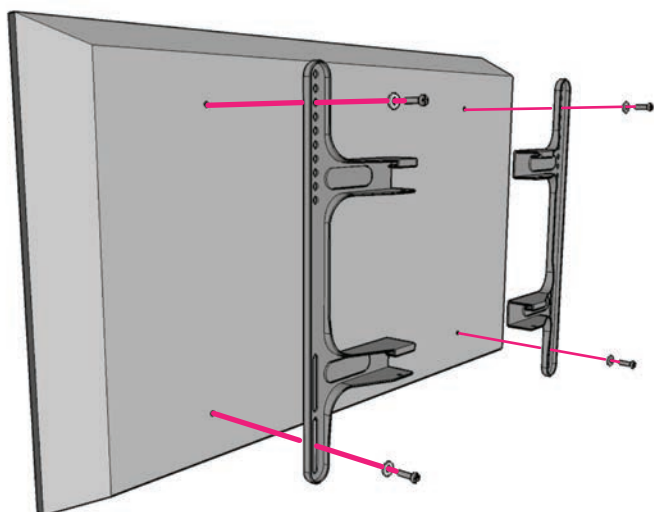

Locate and align the TV mounting holes with the bracket. Use the television screws (⑤ or ⑥) along with the washers (④) and spacers (③) and tighten gently.

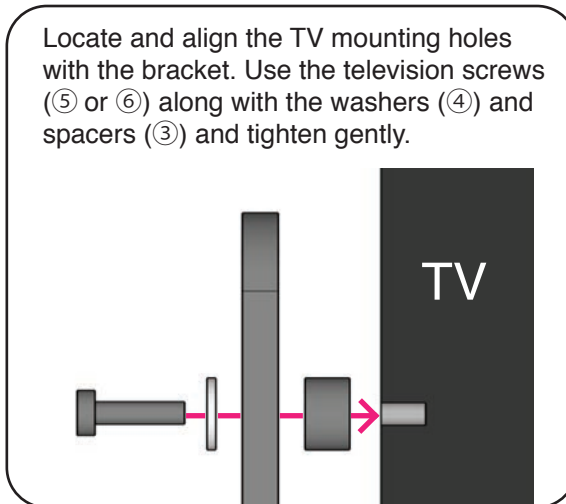

Step 5. Place Television on Rails

Remove the locking blocks and hand screws if they're already in place. Carefully place the television on the rails and make sure it is properly seated in the bracket channels. Someone must brace the television until the locking blocks are secure.

CAUTION!
At least two people are required to safely mount the TV to the rails!

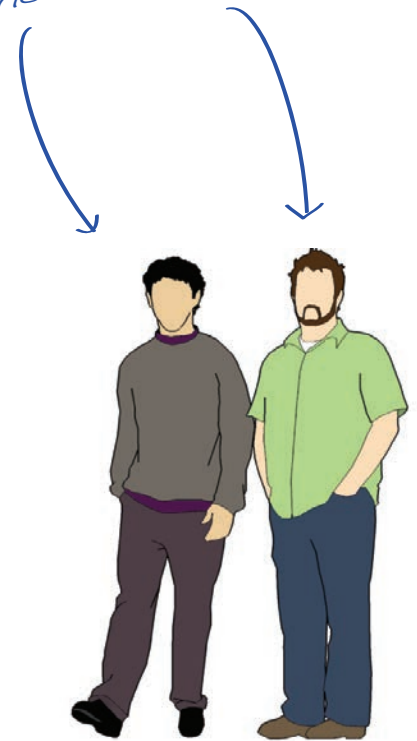

Step 6. Secure Locking Blocks and Handscrews

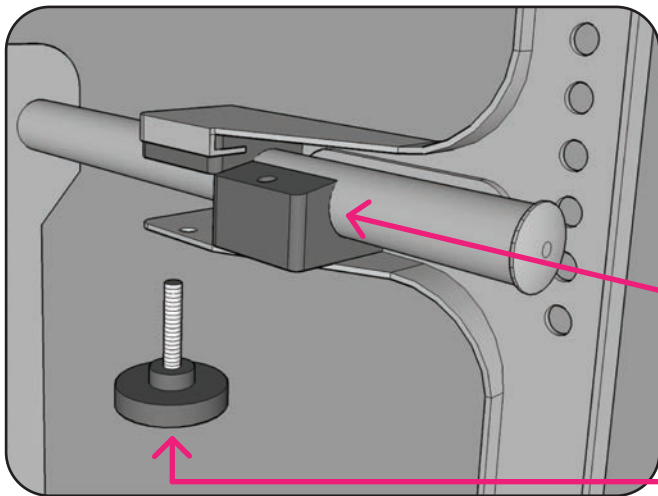

Slide the Locking Blocks into place.

Tighten the Locking Handscrews.

Step 7. Attach AV and power

Attach AV and power cables from your sources to the interface ports at the base of the unit. **DO NOT ATTACH** source cables directly to the TV; **ONLY** attach the TV inputs to the interface ports on the Vertical Post. Make sure to use short cables to avoid snagging.

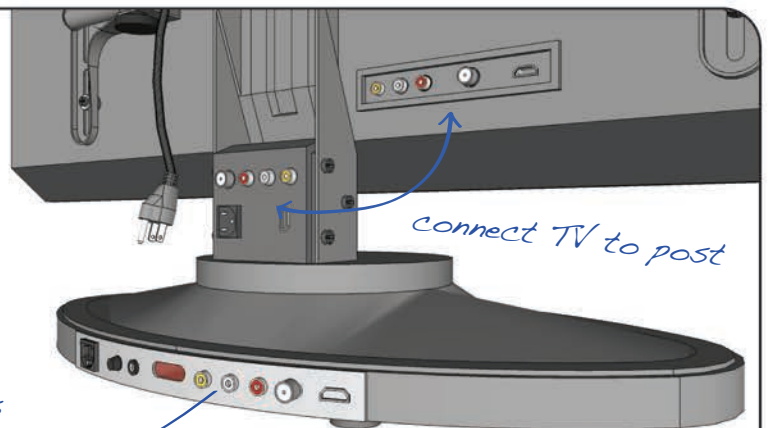

connect base to AV sources

connect TV to post

Power Adapter

Install power adapter (7) in the back of the stand.

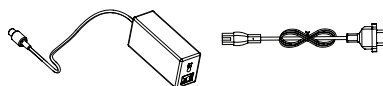

Operation Instructions:

Step 8. Remote Control

Install 23A 12v battery (included) and test operation of the stand.

- To sync the RF remote control, first press the red button located under the base plate, then press the key below ◀◀◀ to sync. To un-sync the RF remote control, first press the red button located under the base plate, then press the key below ◀◀◀ to un-sync.
- Syncing is not necessary for IR remote control.

- 🔓 : first press the unlock key
- ↶ : one click to rotate clockwise 180°
- ↷ : one click to rotate counterclockwise 180°
- ◀◀◀ : press and hold to turn from right to left
- ◀◀◀ : press and hold to turn from left to right

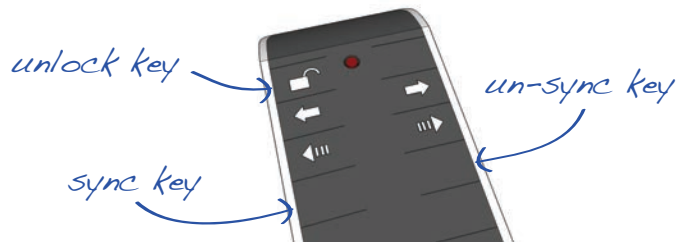

To use RS232/RS485, please visit our website for control codes and software information.
<http://www.pldstudios.com/support>

The bracket is adjusted to rotate a total of 240 degrees (180 degrees plus an additional 30 degrees at each end). The stop point in the rotation is controlled by holding the left or right arrows to the desired location then releasing.

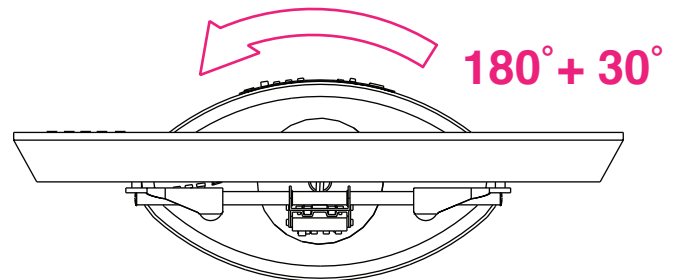
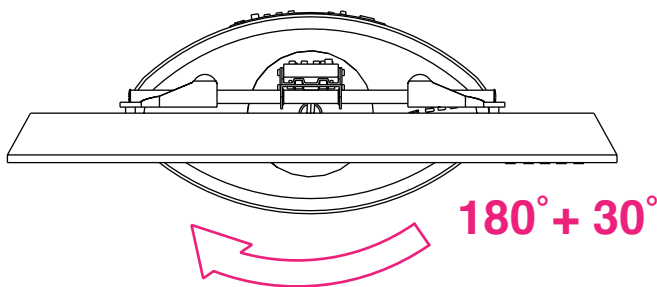

CAUTION!

Please ensure that the area around the television is free from any obstructions that might prevent free movement of the unit, otherwise you may damage the television or motor.

Also make sure that your AV and power cabling are installed so that movement of the television does not cause snagging or damage to your cables or connectors.

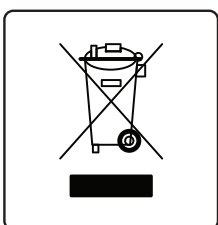

This device contains electronics and other materials which should only be disposed of in a proper disposal facility designed to process electronic waste.

Please help protect our environment:
DO NOT dispose of this unit in household or office trash.



Specifications:

General Specs:

Product Dimension (inch)	Carton Dimension (inch)	Net Weight (lbs.)	Gross Weight (lbs.)
23 $\frac{5}{8}$ x 13 $\frac{1}{8}$ x 27 $\frac{1}{8}$	27 x 16 x 12	36 ± 1	40 ± 1



Electrical Specs:

Rated Voltage	Current (no load)	Current (rated load)	Operation Temperature	Maximum Humidity
DC12V	≤ 0.3A	≤ 0.6A	-20°C to 50°C	80% RH

Operational Specs:

TV Size	Maximum Install Pattern	Minimum Install Pattern	Maximum Bearing Weight	Rotation Range
32" - 65"	860 x 460 (mm)	185 x 135 (mm)	132 lbs.	240° (total)

Certifications:

Submitted to UL Fall 2011	 0434 Approved	 Approved	 Approved
------------------------------	---	---	--

This device complies with part 15 of the FCC Rules. Operation is subject to the following two conditions: (1) this device may not cause harmful interference, and (2) this device must accept any interference received, including interference that may cause undesired operation.

Warranty:

ONE YEAR LIMITED WARRANTY

PLD STUDIOS LLC (hereinafter, "PLD") warrants to original end-users of PLD products that those products will be free from defects in materials and workmanship, under normal use, for a period of one year from the date of purchase by the original end-user. At its option, PLD will repair or replace, or refund the purchase price of, any product that fails during the term of this warranty.

Any implied warranties which may apply are limited in duration to a period of one year from the date of purchase by the original end-user. Notwithstanding the foregoing, PLD specifically disclaims any and all implied warranties, including, without limitation, implied warranties of merchantability and implied warranties of fitness for a particular purpose, with respect to products used for commercial purposes. Some states do not allow limitations on how long an implied warranty lasts, so the above limitation may not apply to you.

This warranty does not cover damage caused by (a) service or repairs by anyone other than PLD or its authorized repair personnel, (b) the failure to utilize proper packing when returning the product, (c) improper installation or the failure to follow the instructions or warnings provided by PLD, or (d) misuse or accident, in transit or otherwise.

In no event shall PLD be liable for incidental or consequential damages or damages arising from the use of, or the inability to use, the product, or criminal or tortious acts by any third party. Some states do not allow the exclusion or limitation of incidental or consequential damages, so the above limitation or exclusion may not apply to you.

This warranty is in lieu of all other warranties, expressed or implied, and is the sole remedy with respect to product defects. No dealer, distributor, installer or other person or organization is authorized to modify or extend this Limited Warranty or impose any obligation on PLD, its resellers or distributors, in connection with the sale of any PLD product.

This warranty gives specific legal rights, and you may also have other rights which vary from state to state.

To ask any questions or to obtain service under this warranty, please contact PLD at 415-992-6620, or contact support@pldstudios.com to describe the nature of the warranty issue and to obtain a Return Material Authorization (RMA) number with instructions for returning the product to PLD. Under no circumstances will PLD will accept any returned product without a previously-issued "Return Materials Authorization" number.