

ISO-MAX[®]

JT-MS-8N3

8 Channel 3 Way Microphone Splitter
with Phantom Power Circuitry

USER MANUAL
Revision 2.0

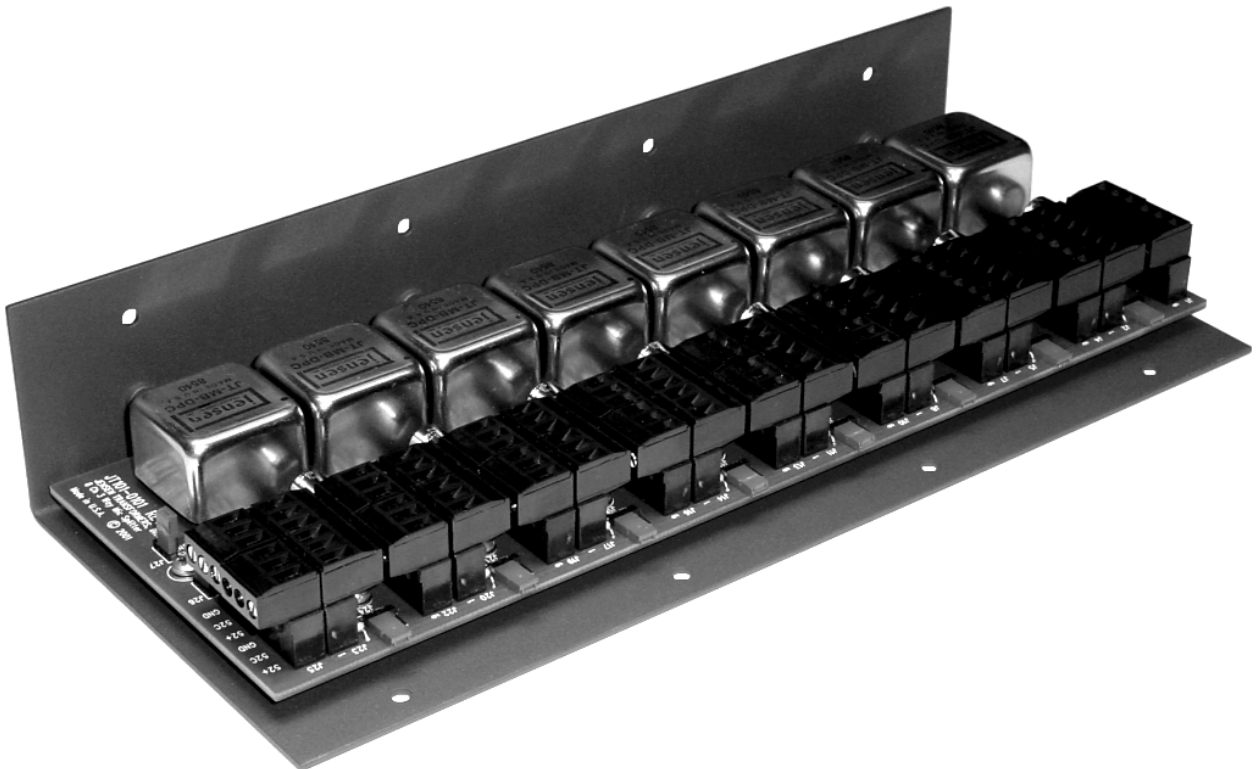

Table of Contents

Section 1 - Introduction	3
Section 2 - Installation	
2.1 Circuit Description and Jumper Settings	
Figure 2.1 - Schematic Diagram	4
2.1.1 Reference Designators	4
2.1.2 Input / Output Connections	4
2.1.3 Phantom Power Circuitry and Switches	4
2.1.4 Ground Lift Circuitry and Switches	5
2.2 Power and Ground Wiring	
2.2.1 Chassis and Groundplane Connections	5
2.2.2 Phantom Power Supply Connections	5
2.3 Input and Output Wiring	
2.3.1 Input Wiring	6
2.3.2 Output Wiring	6
Figure 2.3 - Component Layout	6
2.4 Mounting	
2.4.1 Rack Panel Mounting	7
2.4.2 Bulkhead Panel Mounting	7
Figure 2.4.1 - Rack Panel Drilling Guides	7
Section 3 - Specifications and Physical Dimensions	
3.1 Electrical Specifications	
3.1.1 Frequency Response	8
3.1.2 Level Handling and Distortion	8
3.1.3 Input Impedance	8
3.1.4 Losses	8
3.1.5 Common Mode Rejection Ratio	8
3.1.6 Phantom Power Requirements	8
3.2 Mechanical and Environmental Specifications	
3.2.1 Dimensions	9
Figure 3.2.1 - Mechanical Dimensions	9
3.2.2 Weight	9
3.2.3 Temperature Range and Humidity	9
Section 4 - Warranty	10

Section 1 - Introduction

The Jensen JT-MS-8N3 provides 8 channels of extremely high quality 3 way microphone splitting with 48 Volt phantom power individually selectable on each channel. This functionality is provided in a compact 11.35"W x 4.75"H x 2.25"D package allowing 7 units (56 channels) to be mounted vertically on a 7U size rack panel (see Figure 2.4.1). Excellent frequency response and extremely low distortion are provided by the Jensen JT-MB-DPC microphone splitting transformers that are used in the JT-MS-8N3.

Features:

- 8 Channels of Microphone Splitting/Isolation
- Removable Screw Terminal I/O Connectors
- Input, Direct Output and 2 Isolated Outputs per Channel
- Individual Faraday Shields on All Inputs and Outputs for Maximum Noise Immunity
- Ground Lift Switches Provided for Input and Each Output
- Switchable Phantom Power Circuitry Provided on all Channels
- Typical Distortion of only 0.001% at 1kHz
- Extremely Wide 0.5Hz to 100kHz Bandwidth
- Compact Form Factor Allows High Packaging Density
- Rugged Steel Frame and 0.093" PCB Provide Added Durability

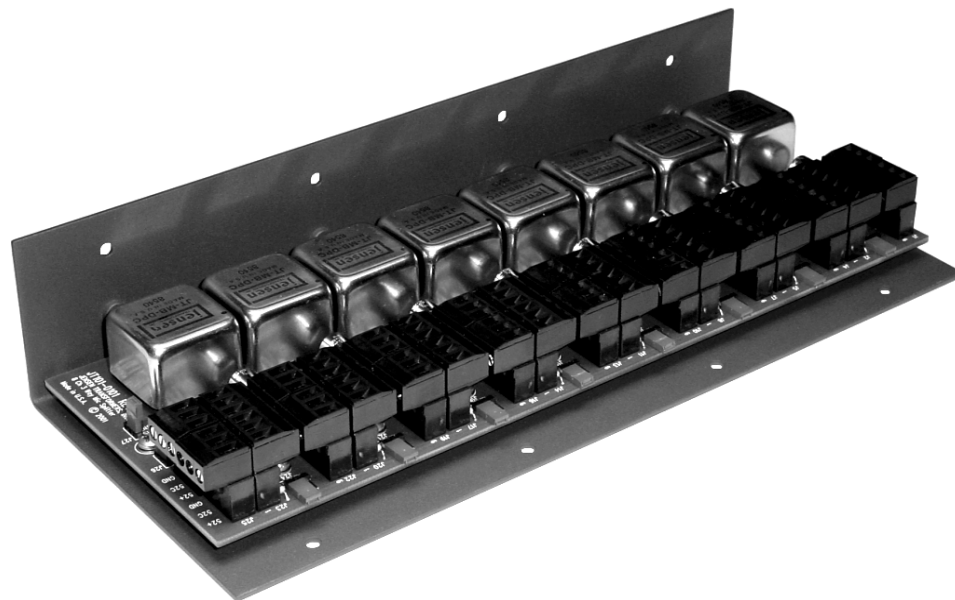

Section 2 - Installation

2.1 Circuit Description and Jumper Settings

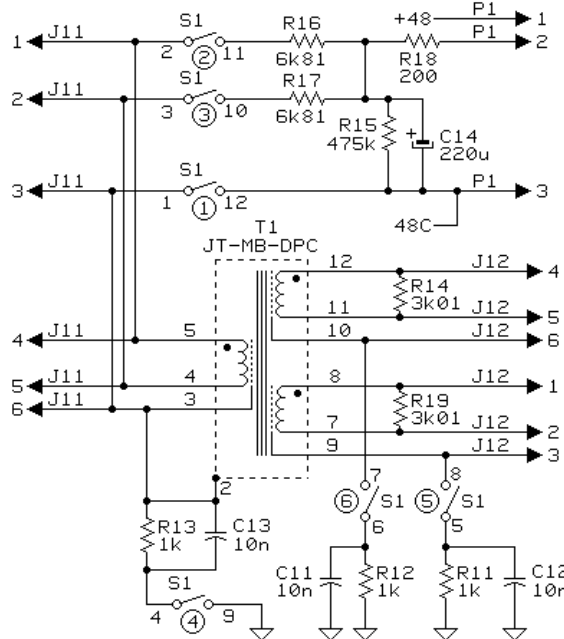

Figure 2.1 - Schematic Diagram (Typ of 8)

2.1.1 Reference Designators

The schematic diagram shown in Figure 1 is representative of each of the eight channels of the JT-MS-8N3 Microphone Splitter. Reference designators for the other seven channels are determined as follows: Switch, transformer and plug reference designators correspond to the channel number, while resistor, capacitor and jack reference designators are formed by adding a digit representing the channel number ahead of the nominal part reference number. For example, channel 1 resistors are numbered R11, R12 ... R19 and channel 3 capacitors are numbered C31, C32 ... C34.

2.1.2 Input / Output Connections

The JT-MS-8N3 is based upon the Jensen JT-MB-DPC microphone splitter transformer, which has a Faraday shielded input winding and two Faraday shielded output windings. Connections for the input winding and a parallel through connection are provided on connector **J11**. Connections for the two isolated output windings are provided on **J12**. A three pin removable plug for each input and output is provided with the **JT-MS-8N3** unit.

2.1.3 Phantom Power Circuitry and Switches

Each of the eight channels are provided with the circuitry and switching necessary to provide standard 48 Volt phantom power to the microphone input. All eight channels share a common phantom power supply. A 3 pin header, **P1**, is provided on each channel for attachment of an SPDT switch if phantom power must be turned on and off frequently. Components **R18** and **C14** provide filtering to prevent “on-off” transients and to remove any residual noise from the

phantom power supply before it reaches the microphone input. Resistor **R15** discharges **C14** to ground if the connections to **J13** are left open inadvertently. Resistors **R16** and **R17** provide the phantom power to the microphone input and are precision matched to maintain balanced common mode input impedances. Dipswitch positions **S1-1**, **S1-2** and **S1-3** allow the phantom power connections to be either connected or completely disconnected from the microphone input. Under normal circumstances, these three switches should be either all **ON** or all **OFF**.

2.1.4 Ground Lift Circuitry and Switches

Ground switching is provided for each individual input and output to allow maximum flexibility in the grounding and termination of the splitter transformer shield connections.

Dipswitch **S1-4** controls whether the microphone input shield is floating or connected to ground through a low impedance network. Resistor **R13** provides a low impedance to ground at low frequencies and capacitor **C13** provides a low impedance to ground at high frequencies when **S1-4** is in the default **ON** position. This low impedance network is used, instead of a hard ground connection, to limit circulating currents between devices that might potentially create a ground loop problem.

Dipswitch positions **S1-5** and **S1-6** connect the isolated output winding shields of the microphone splitter transformer to ground through low impedance networks consisting of **R11**, **C12**, **R12** and **C11** when the switches are in the **ON** position. The default position of **S1-5** and **S1-6** is **OFF**, to simulate a floating microphone at the isolated output.

2.2 Power and Ground Wiring

2.2.1 Chassis and Groundplane Connections

The **JT-MS-8N3** incorporates a groundplane on the top (component side) of the printed circuit board to provide a very low impedance for the individual input and output ground dipswitch connections. This groundplane is normally connected to the steel chassis plate by the default jumper connection at **P10**. If alternate grounding connections are required for some reason, this jumper may be moved to its alternate position, and the groundplane connection may be hard-wired through the **GND** terminals on **J91**. Wire sizes between 14 and 26 gauge, either stranded or solid, may be used to make connections to the **JT-MS-8N3**. Stranded wire should be used if connections will be subjected to repeated movement or vibration, to prevent breakage.

2.2.2 Phantom Power Supply Connections

The **JT-MS-8N3** is designed to be used with a 48 Volt to 52 Volt phantom power supply. Normally, a 48 Volt supply will work fine. In some cases though, when using microphones that require the maximum 48 Volt power to be available for proper operation, the phantom power supply may need to be adjusted to 52 Volts to overcome the slight drop in voltage that occurs across the transient filtering network consists of **R18** and **C14**.

A power supply with a floating (transformer isolated) secondary, such as a typical linear AC-DC supply, should be used to prevent creating any inadvertent paths to ground. The positive terminal of the power supply should be connected to the **48+** terminal of **J91**. The negative, or common, terminal of the power supply should be connected to the **48C** terminal of **J91**. Parallel through connections are provided on **J91** to facilitate “daisy-chaining” of the phantom power connections when utilizing multiple **JT-MS-8N3** assemblies. Wire sizes between 14 and 26 gauge, either stranded or solid, may be used to make connections to the **JT-MS-8N3**. Stranded wire should be used if connections will be subjected to repeated movement or vibration, to prevent

breakage.

Under normal circumstances, the low side of the phantom power supply, **48C**, is connected directly to the groundplane, **GND**, through the jumper at **P9**. If this needs to be changed for some reason, the jumper may be moved to its alternate position, and the phantom power supply common, **48C** on **J91**, may be connected to some other reference point.

2.3 Input and Output Wiring

In order to avoid wiring confusion, the HI, LO and SHIELD connections are arranged in the same order for each of the INPUT, THRU, OUTPUT 1 and OUTPUT 2 connector positions.

2.3.1 Input Wiring

INPUT and THRU connections are provided on pins 1 through 6 of **J11**:

INPUT HI, LO and Shield connections are on pins 1, 2 and 3 respectively.

THRU HI, LO and Shield connections are on pins 4, 5 and 6 respectively.

2.3.2 Output Wiring

Isolated Output connections are provided on pins 1 through 6 of **J12**.

OUTPUT 1 HI, LO and Shield connections are on pins 1, 2 and 3 respectively.

OUTPUT 2 HI, LO and Shield connections are on pins 4, 5 and 6 respectively.

Wire sizes between 14 and 26 gauge, either stranded or solid, may be used to make connections to the **JT-MS-8N3**. Stranded wire should be used if connections will be subjected to repeated movement or vibration, to prevent breakage.

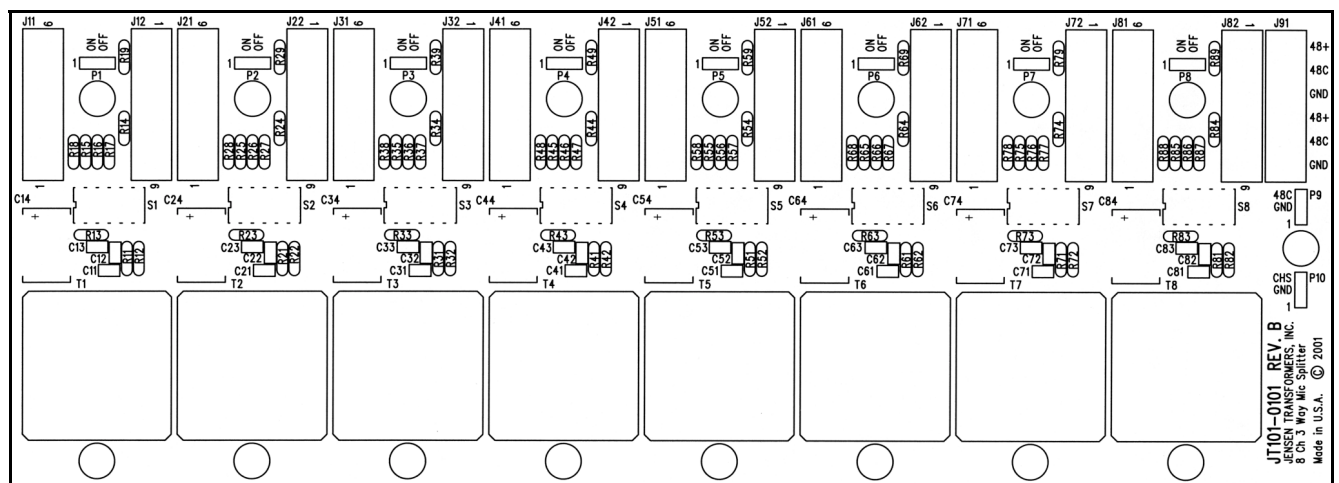

Figure 2.3 - Component Layout

2.4 Mounting

The JT-MS-8N3 is equipped with three sets of mounting holes to provide the flexibility required to accommodate many different types of installation requirements. It may be mounted either vertically or horizontally on a 19" rack type panel or it may be secured to a wall or bulkhead.

2.4.1 Rack Panel Mounting

Four 8-32 PEM type fasteners are provided along the bottom mounting flange of the JT-MS-8N3 for mounting to standard 19" rack panels. A single JT-MS-8N3 unit may be mounted horizontally to a 2U rack panel. Up to seven JT-MS-8N3 units may be mounted vertically to a 7U rack panel. See **Figure 2.4.1** for 2U and 7U rack panel drilling guides.

2.4.2 Bulkhead Panel Mounting

Four 0.172" diameter mounting holes are provided along the bottom mounting flange and along the top edge of the JT-MS-8N3 for mounting the unit with the printed circuit board either parallel to or perpendicular to a bulkhead or wall. If the unit is mounted with the printed circuit board parallel to the bulkhead or wall, four right angle mounting brackets may be also used to attach the bottom flange to the wall for additional rigidity.

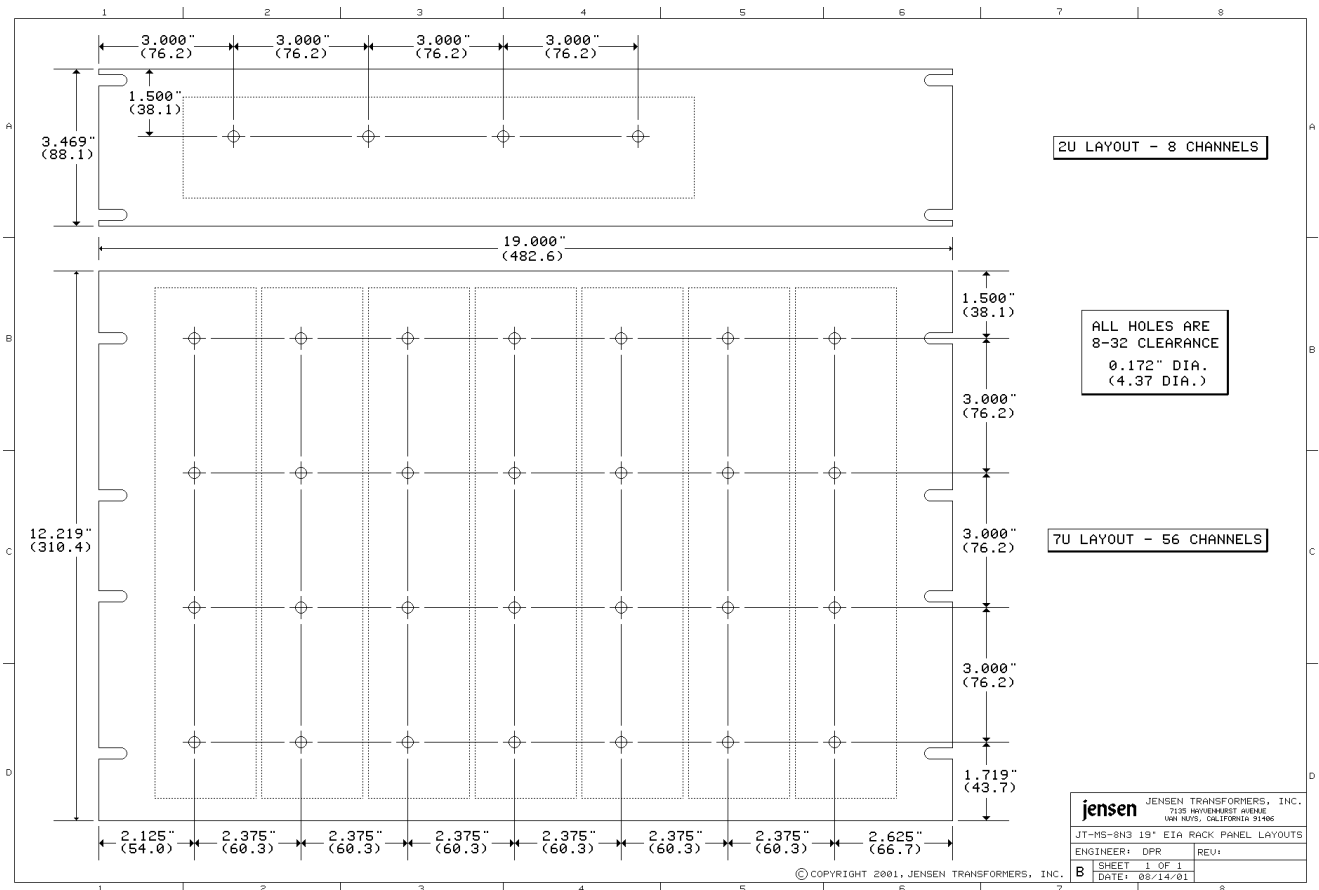

Figure 4.2.1 - Rack Panel Drilling Guides

Section 3 - Specifications

3.1 Electrical Specifications

3.1.1 Frequency Response (150 Ohm source, 1500 Ohm preamp load at each isolated output)

High Frequency -3dB Cutoff	
Isolated Output 1	108kHz
Isolated Output 2	130kHz
Low Frequency -3dB Cutoff	
Isolated Output 1	0.4Hz
Isolated Output 2	0.4Hz
20Hz / 20kHz Response re: 1kHz	
Isolated Output 1	-0.10dB / -0.10dB
Isolated Output 2	-0.10dB / -0.04dB

3.1.2 Level Handling and Distortion

Maximum 20Hz Input Level at 1% THD	+2dBu (0.975V)
Maximum 50Hz Input Level at 1% THD	+10dBu (2.449V)
Total Harmonic Distortion at 20Hz and -20dBu	0.05%
Total Harmonic Distortion at 1kHz and -20dBu	0.001%

3.1.3 Input Impedance

Input Impedance with no preamp loads	1.52k Ohms
Input Impedance with 1 1500 Ohm preamp load	818 Ohms
Input Impedance with 2 1500 Ohm preamp loads	569 Ohms

3.1.4 Losses

Output with 1500 Ohm preamp load referenced to Input	
Isolated Output 1	-1.32dB
Isolated Output 2	-1.25dB

3.1.5 Common Mode Rejection Ratio

60Hz CMRR	
Isolated Output 1	120dB
Isolated Output 2	110dB
3kHz CMRR	
Isolated Output 1	90dB
Isolated Output 2	80dB

3.1.6 Phantom Power Requirements

Nominal Input Voltage	48 Volts
Maximum Input Voltage	56 Volts
Nominal Phantom Current (Total of 8 Channels - 48 Volts)	53 milliamps
Maximum Phantom Power Current (All 8 Channels Shorted - 56 Volts)	125 milliamps

3.2 Mechanical and Environmental Specifications

3.2.1 Dimensions

Length	11.35 Inches (288.3 mm)
Width	4.75 Inches (120.6 mm)
Height	2.25 Inches (57.1 mm)

3.2.2 Weight

Net Weight (Including all 34 Plug-in Connectors and Mtg. Screws)	3.75 lb. (1.70 kg.)
Shipping Weight	4.5 lb. (2.1 kg.)

3.2.3 Temperature Range and Humidity

Operation or Storage Temperature	32° to 158° Fahrenheit (0° to 70° Centigrade)
Humidity	10% to 90% non-condensing

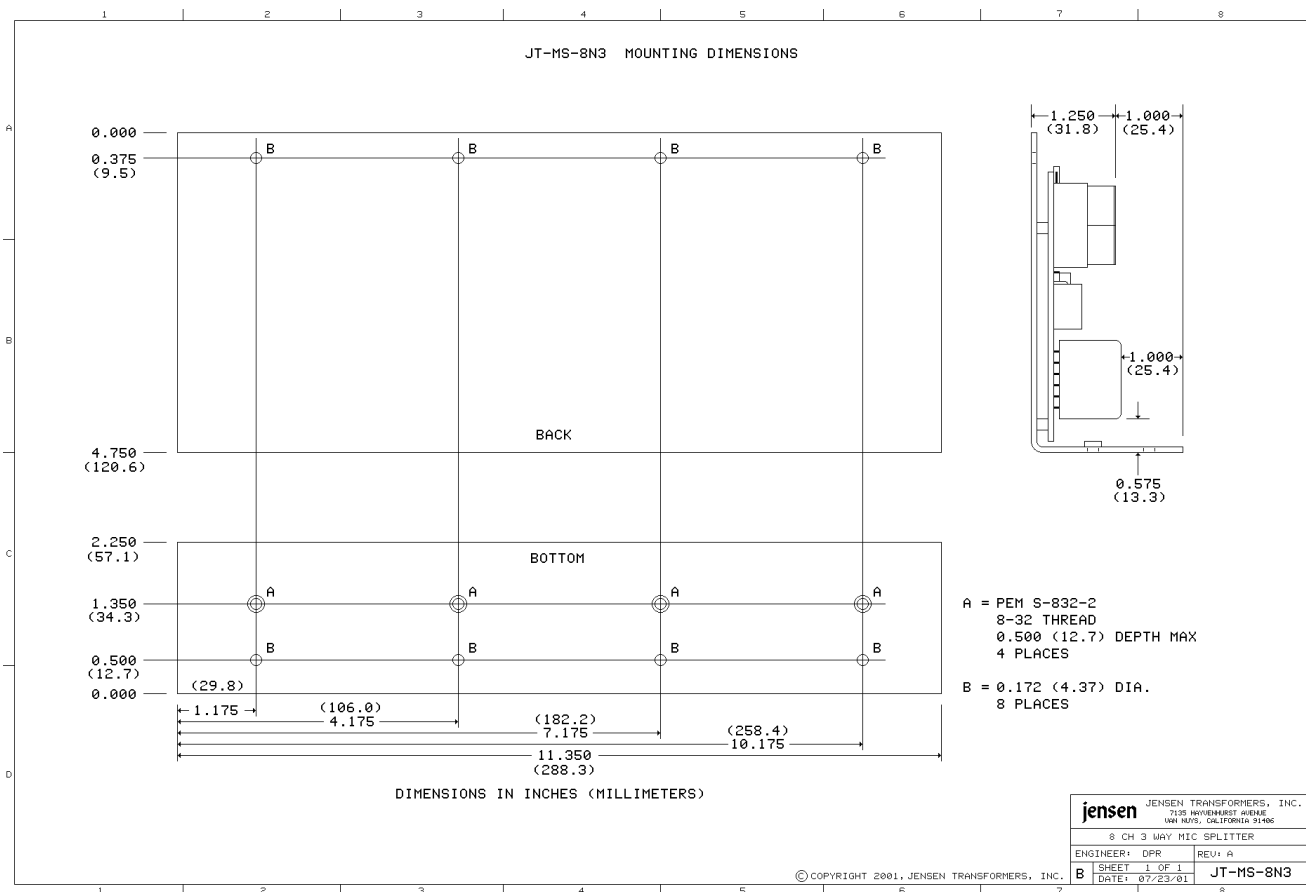

Figure 3.2.1 - Mechanical Dimensions

Section 4 - Warranty

For a period of 1 YEAR after purchase, Jensen Transformers, Inc. will, free of charge, repair or replace any part of an ISO-MAX® product that fails due to defective materials or workmanship.

For a period of 20 YEARS after purchase, Jensen Transformers, Inc. will, free of charge, repair or replace any Jensen OEM transformer or any Jensen transformer contained in an ISO-MAX® product that fails due to defective materials or workmanship.

Both limited warranties are subject to the following limitations:

- 1) Defects that are, in the sole judgement of Jensen, the result of accident, misuse, abuse, neglect, mishandling, misapplication, faulty installation, unauthorized repair, modification, or acts of God will not be covered by this warranty.
- 2) In the absence of proof of date of purchase, the date of manufacture (as determined from lot numbers of internal parts and the records of Jensen Transformers, Inc.) shall be used in its place.
- 3) There are no express warranties except as listed above.
- 4) JENSEN TRANSFORMERS, INC. SHALL NOT BE LIABLE FOR INCIDENTAL OR CONSEQUENTIAL DAMAGES RESULTING FROM THE USE OF THIS PRODUCT OR ARISING OUT OF THE BREACH OF THIS WARRANTY. Duration of implied warranties, if any, is limited to 12 months. If a problem develops with this product during the warranty period, call or write us before attempting any repair. We can help you identify specific problems, and possibly solve the problem, before the unit is returned to us for repair or replacement. In any case, DO NOT RETURN THE UNIT WITHOUT AUTHORIZATION and instructions from us. Jensen cannot be responsible for damage due to shipping or improper packaging.

Limitations of Liability

The information provided by Jensen about its products been checked and is believed to be accurate; however, no responsibility is assumed by Jensen for its use nor for any infringements of patents which may result from its use. No license is granted by implication or otherwise under any patent or patent right of Jensen Transformers, Inc.

JENSEN PRODUCTS ARE NOT AUTHORIZED FOR USE AS CRITICAL COMPONENTS IN LIFE SUPPORT DEVICES OR SYSTEMS, OR IN ANY APPLICATION WHERE THEIR FAILURE COULD CAUSE INJURY OR DEATH.

Jensen reserves the right to make changes without further notice to any of its products. Jensen makes no warranty, representation or guarantee regarding the suitability of any of its products for any particular purpose, nor does Jensen assume any liability arising out of the application or use of any product or circuit, and specifically disclaims any and all liability, including without limitation consequential or incidental damages.