



SF-16 FEATURES:

- The perfect companion to ADX and HLX audio matrix switchers - audio connections can be made in seconds using the included quick-connect DB25 cable
- 8 stereo/16 mono RCA inputs for connection of standard audio sources or third-party whole-house audio systems
- 2 Cat5 wall plate inputs accept optional stereo RCA, mono balanced and paging mic audio wall plates (sold separately)
- Audio wallplates can be located up to 1,000 feet away and include provisions for amp channel audio override and IR pass-through
- Override feature provides special functions such as paging capabilities, local source selection, and room combining
- 16 high-power speaker outputs (60W @ 8 Ohms) which can be assigned any direct, bus or Cat5 input as stereo or mono
- 10 preset sound scenes, which can be saved and recalled using IR, RS-232 or IP commands - ideal for quick recall of volume settings in standalone SF-16 applications
- DB25, Cat5 audio, IR and RS-232 loop outs for daisy chaining up to four SF-16 amplifiers (64 outputs total)
- Open control architecture allows any IR, RS-232 or IP based controller to adjust volume, muting, audio override, and sound scenes
- Full front panel control and setup via touch panel and simple rotating multi-function knob
- 3U rack mount ears included

Flexible Applications, Robust Audio Performance

Audio Authority's SonaFlex SF-16 is a unique blend of multi-channel amplification, flexible audio routing, and open control capability. Built and designed in the U.S. with the custom installer in mind, the SF-16 brings a new approach to common residential and commercial distributed audio applications. With its numerous input/output configurations, the SF-16 can be as simple or advanced as you need it to be.

Remote wall plates, designed to accept consumer and pro audio sources such as iPods, microphones, audio mixers, and paging microphones, connect to two Cat 5 inputs on the SF-16. Wall plates can be located up to 1,000 feet away from the SF-16 and include provisions for amp channel override and IR pass-thru for control.



Compatible Cat5 Audio Wall Plates



STEREO RCA
Model RA-U

BALANCED
Model RA-B

PAGING STATION
Model RA-PM

Connections to Audio Authority's ADX and HLX audio matrix switchers couldn't be simpler. Using the included quick-connect DB25 cable, source audio connections are completed in minutes instead of hours. When standard audio sources or third-party whole-house audio systems are required, the SF-16 also includes eight stereo RCA inputs.

Other unique features include 10 programmable volume presets, as well as control of all SF-16 presets, channel volume, muting and audio override from virtually any IR, RS-232 or IP based controller.

SF-16 Installation Applications:

WHOLE-HOUSE AUDIO WITH LOCAL SOURCE OVERRIDE

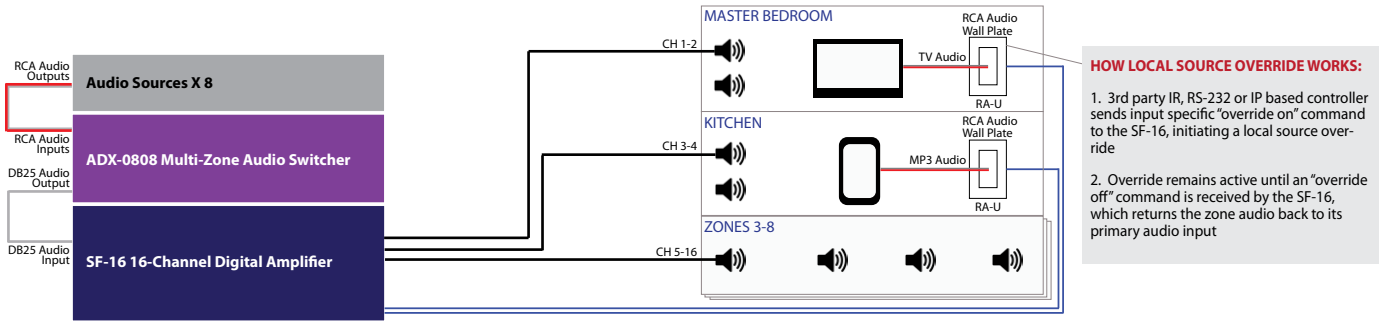

RESTAURANT/BAR/HOSPITALITY - AUDIO DISTRIBUTION & PAGING

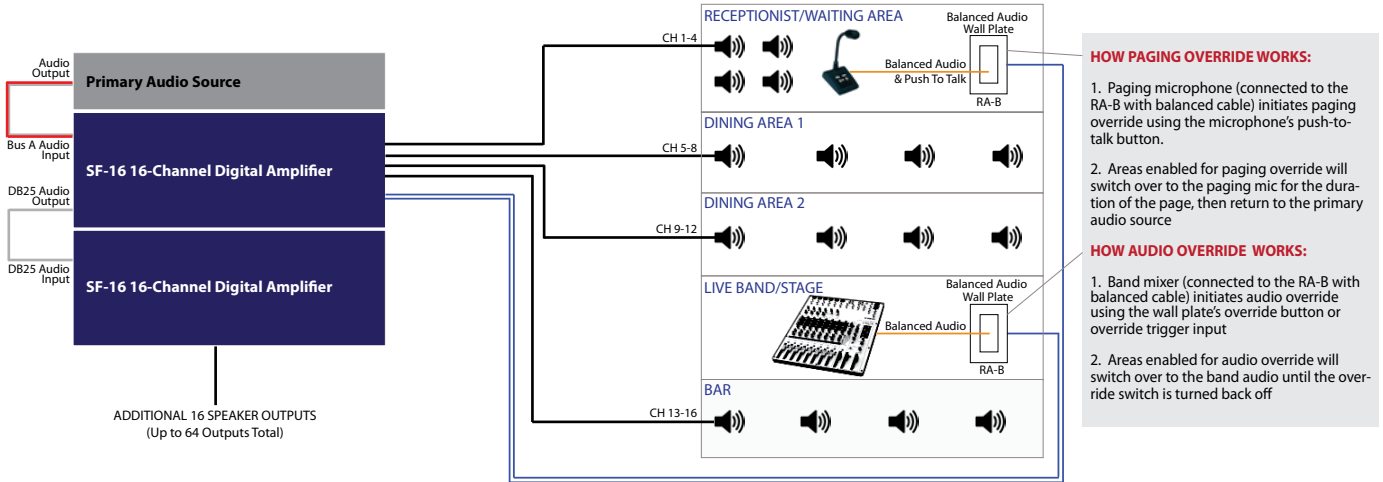

CONFERENCE CENTER/HOUSE OF WORSHIP - ROOM COMBINING

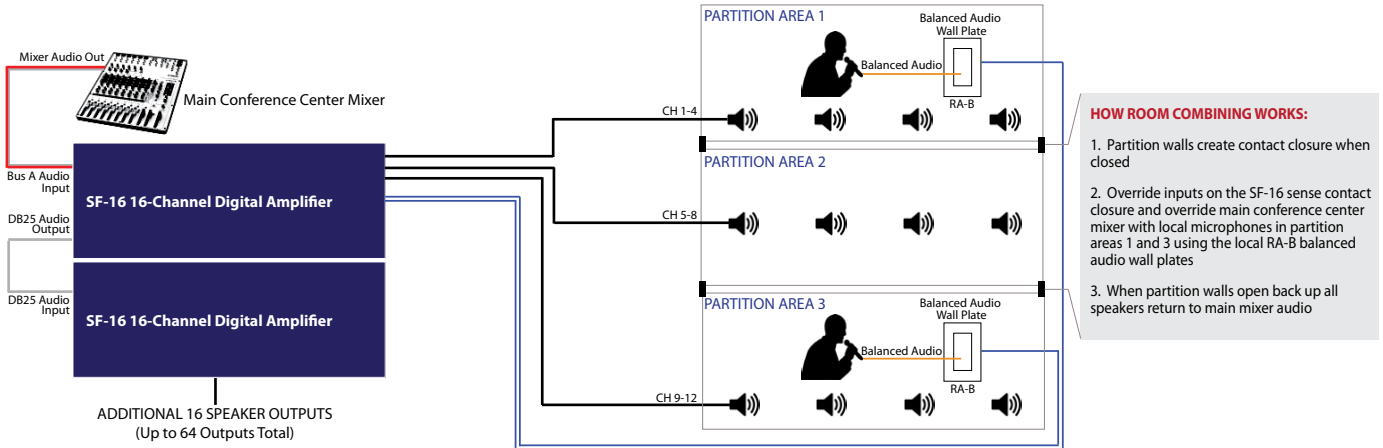

SF-16 SPECIFICATIONS:

Continuous Power Per Channel (RMS): 60W @ 8 Ohms, 80W @ 4 Ohms
 Frequency Response 20Hz to 20kHz, +/-3db into 8 Ohms
 Full Power Bandwidth 20Hz to 20kHz
 S/N Ratio 96dB
 Channel Separation 70dB(channel to channel @1kHz)
 Total Harmonic Distortion 0.05% THD+N at full power
 Intermodulation Distortion 0.05%

Input Impedance 10k Ohms
 AC Power Requirements 1200W
 Current Draw 10A RMS
 Heat Output 38/68 BTU/hr
 Dimensions (H x W x D) 5.22" x 16.60" x 14"
 Warranty One year, parts and labor



ADX-1616 Audio Matrix

FEATURES:

- Sixteen source input / sixteen zone output (ADX-1616) or eight source input / eight zone output (ADX-0808) matrix switcher
- Ethernet, RS-232 Serial and IR (Front & rear panel) control
- Integrates seamlessly with third party control systems from Control4, URC, RTI and more
- IR and RS-232 codes available for use with virtually any third party control system
- Full front panel control with unique capacitive touch surface and simple rotating multi-function knob
- Custom settings *per zone*: 10-band EQ, Tone (Bass/Treble) and Balance
- Zone grouping (10 groups) and Source/Zone combination presets (10 source/zone combinations)
- Global source selection (switch all zones to same source)
- Front panel lockout
- Simple PC-based setup via Ethernet, serial or USB drive
- 2U rack mount ears included

Multiple Control Options

Virtually any control system or programmable remote can take full advantage of audio switching, EQ settings, zone grouping, lockout and more. Basic functions of the ADX Series Audio Switchers can be controlled with IR via 3.5mm and terminal connectors or via the IR receiver on the front.



Ethernet control via PC or other IP control system.



RS-232 for standard serial control.



Standard 3.5mm IR jack or terminal connection.

A Powerful Tool For Your AV Arsenal

Affordable, integration-friendly, and an audio lover's dream! With ground-breaking DSP capabilities at a break-through price point, the ADX Series Audio Matrix Switchers truly belong in your next audio-video installation.

Featuring custom 10-band EQ control **per zone**, the ADX Series brings your customer new levels of audio performance and control. With remote two-way feedback and third party control of all DSP settings from any zone, you can now satisfy even the most discriminating audiophile.

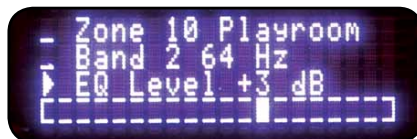

Custom 10-band EQ Per Zone

Customizing ADX

ADX Series Audio Switchers are easy to install right out of the box with virtually no setup required for basic functionality. Using our simple PC setup software or front panel controls, integrators can quickly perform advanced setup tasks such as naming each source input and zone output for display on the front panel. "Favorites" can be designated for specific scenes, such as game night, party, or movie night. "Groups" are useful for such tasks as switching all downstairs zones to a certain source, for example. In addition, all settings can be backed up to a USB flash drive.

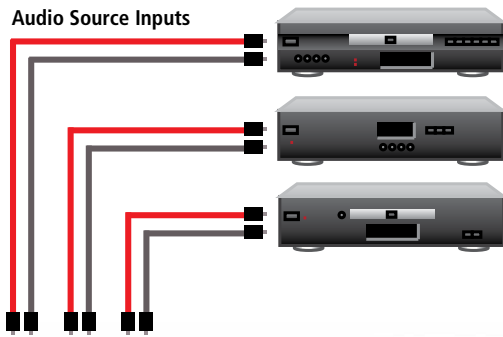

ADX™ / SONAFLEX™ SIGNAL FLOW:

The quick ADX DB-25 connector makes installation a snap with the new SonaFlex™ 16 channel amplifier by Audio Authority. The FlexPort wallplates are an easy way to override any zone's audio with a local source such as an iPod™ or game system.



ADX-1616

ADX Zone Outputs 9-16 to SonaFlex™ Amplifier



SF-16 Amplifier

Speaker Outputs To Zone Speakers

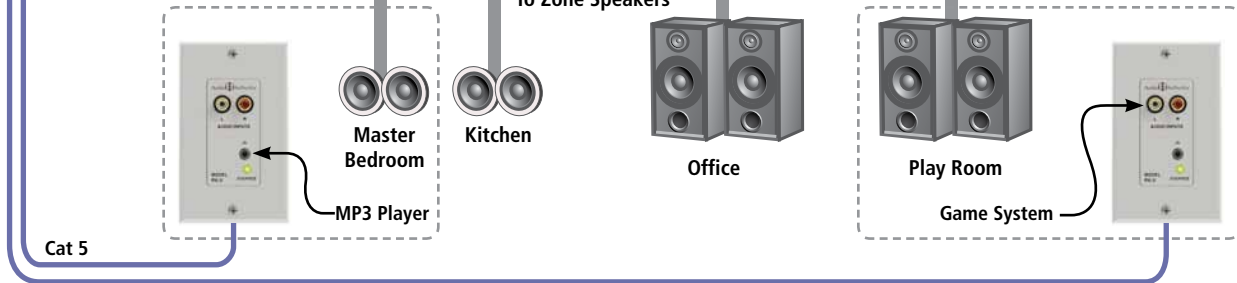

ADX-0808 / ADX-1616 SPECIFICATIONS:

Audio Inputs	Left and Right RCA stereo
Input Impedance	100K
Minimum Load Impedance	10K
Frequency Response	10-25kHz
S/N Ratio	82dB
THD+Noise	0.02%
Crosstalk	85dB
Agency Approvals	FCC

DC Input Connector	5.5 x 2.1mm
DC Input Voltage/Polarity	18V/Center Positive
Max DC Input Current	600mA/1.1A
Power Supply	571-014/571-023
Heat Output	38/68 BTU/hr
Net Product Weight	9.9
Shipping Weight	11.4
Dimensions (H x W x D):	3.5" x 16.5" x 8.25"
Warranty	One year, parts and labor